

INTERNATIONAL HOBIE CLASS ASSOCIATION
2005-2008 CLASS RULES
(As amended 1st April 2005)

INTRODUCTION

For some sailors, Hobie racing is about competition and the exhilaration of winning (or losing) fairly. For others, it's the challenge, excitement, concentration and physical exertion. But for the vast majority of Hobie sailors, it's about fun, camaraderie, familiar places, new places, old friends and new, and memories of fun times with people who share a love of the sport.

Like any worthwhile activity in life, there is a right way and a wrong way to participate in Hobie sailing. The Hobie Class Rules set forth in this booklet, and the ISAF Racing Rules of Sailing (RRS) as distributed by your National Sailing Federation, are your guidelines to the right way to race ... the Hobie way.

The rules of sailing are designed to allow all of us to compete fiercely and fairly with each other on a level sea. The rules are important for all sailors, but particularly so for one-design Hobie Cat sailors. Each of us has a basic responsibility to be familiar with the rules. Read them, accept them and abide by them—and we'll all have more FUN.

Be proud of your Class! Participate and become friendly with your Hobie competitors! Share your experiences and good times on and off the water with every new Hobie sailor you meet!

Welcome to the Hobie Way of Life! We wish you fair winds and many happy days of great sailing.

Table of Contents

INTERNATIONAL HOBIE CLASS ASSOCIATION GENERAL RULES.....	3
HOBIE DRAGOON CLASS RULES	10
HOBIE WAVE CLASS RULES	12
HOBIE 14 CLASSIC / 14 TURBO CLASS RULES	13
HOBIE 16 CLASS RULES.....	15
HOBIE 17 CLASS RULES.....	18
HOBIE FX-ONE CLASS RULES	19
HOBIE 18 / HOBIE 18 MAGNUM / HOBIE SX-18 / HOBIE 18 FORMULA CLASS RULES.....	21
HOBIE TIGER CLASS RULES.....	24
HOBIE 20 CLASS RULES.....	27
HOBIE 21 CLASS RULES.....	29
HOBIE FOX CLASS RULES	32
Appendix A TRAPSEAT GUIDELINES FOR THE HOBIE 16	35
Appendix B IHCA Supplement to the International Hobie Cat 16 Class Rules.....	36
Appendix C IHCA Measurers Administration.....	38
Appendix D IHCA Contacts	39

INTERNATIONAL HOBIE CLASS ASSOCIATION GENERAL RULES

These Rules apply to all Hobie Classes

ISAF International Classes are the HOBIE Dragoon, 14,16,17,18 & Tiger

1. ONE-DESIGN CLASS RACING

The design and development of Hobie Catamarans are directed towards strict one-design classes where the true test is between sailors and sailing skill, and not boats. Any alterations to the hull form, construction, equipment, spars, sails or running rigging, as supplied by the builder except as is specifically authorized by these rules, are a breach of these rules, both in spirit and in substance, and are prohibited.

2. INTENT AND OBJECTIVE

Hobie Catamarans are designed to be easy to sail with the least amount of trouble to owners. Boat and component changes, which have no direct bearing upon boat speed, are the only changes allowed. The intent and objective of the INTERNATIONAL HOBIE CLASS ASSOCIATION (IHCA) RULES are:

- a) To keep each boat as equal, simple and cost free as possible by rigidly maintaining, without deviation, the one-design features of the Hobie Cat for class racing.
- b) To increase boat speed only through the use of racing tactics and sailing skills

2.1 DEFINITIONS

- a) The International Hobie Class Association shall hereafter be referred to as IHCA.
- b) Hobie Cat USA, Hobie Cat Europe and any of their licensees that are in good standing with their respected licensors shall hereafter be referred to as HOBIE CAT CO.
- c) International Sailing Federation shall be referred to as the ISAF.
- d) The International Sailing Federation Racing Rules shall be referred to as the RRS.

3. MEASUREMENT

- a) The IHCA and its designated measurers are the measurement authority for the Hobie Class under the meaning of RRS 64.3 b). The IHCA has the right to declare ineligible any Hobie Cat, which does not conform to the spirit, objective and intent, as well as the letter of these rules and the official drawings and specifications held by the ISAF. In the event the drawings are not held by the ISAF

they shall be held by the respective HOBIE CAT CO.

- b) In the case of a dispute alleging non-compliance with the letter of these rules, the official drawings and specifications, the matter, together with any relevant information, shall be referred to the IHCA Rules Committee who shall give a ruling under the provisions of General Class Rule 25.
- c) In the case of a measurement dispute on matters not explicitly covered by these rules, the official drawings and specifications the following procedure shall be adopted:

A sample of 5 other boats shall be taken by the designated measurer and measured using identical techniques. The dimensions of the disputed boat shall be equal to, or between the maximum and minimum dimensions obtained from these 5 boats. If the boat in question is outside these dimensions the matter, together with any relevant information, shall be referred to the IHCA Chief Measurer who shall give a final ruling. If any of the dimensions of the sample are considered to be unusual, all relevant information shall be referred to the IHCA Chief Measurer as well.

4. LOOPHOLES

IF YOU THINK YOU HAVE FOUND A LOOPHOLE, READ THE PRECEDING STATEMENTS AGAIN. THESE ARE THE BASIS OF THE RULES AND COVER ALL AREAS NOT COVERED IN THE RULES. GENERALLY, IF YOU CANNOT FIND IT LISTED IN THE RULES, IT IS NOT CLASS LEGAL. IF YOU ARE IN DOUBT, CHECK WITH THE IHCA FIRST. APPROVAL MUST BE IN WRITING.

5. MANUFACTURER OF HOBIE CATS

- 5.1 "Boats and component parts as originally manufactured by the HOBIE CAT COMPANY are the only ones legal for class racing unless specifically permitted in these Class Rules. The manufacturing origin and trademarks of all boats shall be readily identifiable through serial numbers, hull numbers, sails and cast parts. Copies of original invoices or warranty cards may be requested. Proof of origin shall be submitted to the IHCA or its authorized representatives for verification upon request of the jury or protest

committee. Skippers or owners of boats who have had the manufacturing origin of their boat or component parts protested shall have a maximum of two weeks to produce acceptable proof of origin.”

- 5.2 The ISAF plaques shall be permanently affixed to the transoms for all ISAF recognized classes built after January 1, 1990.

6. NON HOBIE CAT COMPANY MANUFACTURERS OF EQUIPMENT

Manufacturers and distributors of non Original Equipment Manufacturer (OEM) parts and equipment for Hobie catamarans shall obtain written approval from the IHCA prior to their parts and equipment being designated as “Hobie Class Legal.”

7. DESIGN FEATURES AND APPROVED CHANGES

Nothing may be changed or removed from any Hobie Cat that will in any way alter the structural integrity, design function, or built in safety features of the boat. All changes shall have prior written approval. Provided they do not change the basic design and configuration, approved changes are: stronger gudgeons; stronger pig-tails; larger diameter wires and running rigging; reinforced flanges not affecting water flow. Except as allowed in these rules, any changes or additions that in any way can be construed as speed devices are not class legal.

8. SAFETY EQUIPMENT

- 8.1 Each person on board shall carry a lifesaving device or Personal Flotation Device (PFD) approved by their country’s national authority or by the national authority having jurisdiction. The IHCA strongly recommends that life jackets or PFDs be worn at all times.

- 8.2 A minimum* 3/8 in. (9.53 mm) diameter righting line or webbing consisting of at least one 14 ft. (4.27 meter) length of line or webbing, or two 8 ft. (2.44 meter) lengths of line or webbing shall be securely attached and readily accessible from each side of the boat. The righting lines or webbing shall be in addition to all other required equipment. (Unless specified differently in individual boat class rules)

** Righting water bags, shroud lengthening devices, righting pole type devices, and righting systems other than the minimum system specified may be carried and shall be used for righting purposes only.*

- 8.3 A paddle or equivalent is allowed and recommended but not required.

- 8.4 An anchor is not required.

- 8.5 Any additional equipment which may be required by a government or national authority having jurisdiction

9. HULLS, DECKS, AND RUDDERS

- 9.1 Hulls may be rubbed, waxed, sanded or buffed in the normal process of maintenance.

- 9.2 No friction-reducing agents may be employed on the hulls, rudders or boards.

- 9.3 Hull bottoms which wear down may be rebuilt. Rebuilt hulls must conform with the original shape. Templates are available from the HOBIE CAT CO.

- 9.4 No portion of the deck, or deck flange where present, shall be altered, removed, cut down, or in any way modified except as allowed herein. The rear transom flanges, where present, may be notched a maximum of 2 in. (5 cm) to accept larger gudgeons or to repair breakout at the rudder pin. Water tight deck access portholes may be installed.”

- 9.5 Hull flotation blocks as supplied by the HOBIE CAT CO. shall not be removed or reduced in size.

- 9.6 Non-skid surfaces on decks may be changed provided the non-skid surface is at least equal in size and location to the originally designed area.

10. RUDDERS AND RUDDER ASSEMBLIES

- 10.1 HOBIE CAT CO. supplied rudder assemblies and rudder blades shall not be modified except for minimum filing to improve fit and function unless specifically allowed in the individual boat rules.

- 10.2 Shims maybe installed between the rudder blade and rudder housing to improve fit and function.

- 10.3 Shims or bushings may be installed between rudders pins, gudgeons, and castings to improve fit and function.

- 10.4 Shock cord may be tied around the rudder to help control rudder kick up.

- 10.5 Rudder rake adjusters may be installed and upgraded to current HOBIE CAT CO design.

- 10.6 Rudder blades may be notched on the upper leading edge up to a maximum of 1/2 in. (12.5 mm) to correct helm.
- 10.7 The minimum weight of each rudder blade shall be 3.0 lb. (1.36kg)"
- 10.8 Rudder pins may be changed provided the length and diameter of replacement rudder pins are at least the same dimensions or greater than as supplied by HOBIE CAT COMPANY. Pins may be made of plastic, aluminium, nylon, composite, or stainless steel materials.
- 11. TILLER ASSEMBLIES**
- 11.1 The tiller extension may be either an extendable or non-extendable design but shall be a single tiller with one end connected to the crossbar in the same location as the factory supplied tiller. THE TILLER EXTENSION SHALL BE MADE OF A NONELECTRICAL CONDUCTIVE MATERIAL ON ALL NORTH AMERICAN REGION BOATS. NONELECTRICAL CONDUCTIVE TILLER EXTENSIONS ARE RECOMMENDED ON ALL BOATS WORLDWIDE.
- 11.2 Tiller crossbar and rudder arm connectors and end caps may be replaced with other types that are functionally similar.
- 12. SAILS**
- 12.1 Class legal sails shall be made from HOBIE CAT CO official patterns and manufactured and distributed by the HOBIE CAT CO or their currently licensed sail makers unless specified differently in individual boat class rules.
- a) A sail may be recut slightly, provided the overall original size and shape is not increased or altered other than by normal stretch with aging and sail tuning.
- b) Windows and telltales may be added as desired.
- c) A Cunningham may be installed in any sail. The maximum purchase shall not exceed 2:1 unless specified otherwise in the individual boat Class Rules.
- 12.2 Only standard battens supplied by the HOBIE CAT CO shall be used unless specified differently in the individual boat class rules. Battens may be custom cut and tapered as desired.
- a) Any type of batten caps may be used provided they are not adjustable while sailing.
- b) Two battens may be used in the bottom batten pocket of the mainsail.
- 12.3 A skipper shall not change sails during a race or regatta unless his sail has been damaged and is no longer usable. Permission to make a sail change must be received, in writing, from the race committee PRIOR to the change being made.
- 12.4 All mainsails shall have a sail number assigned by Hobie Cat Company and registered with the IHCA. Duplicate numbers will be assigned to only one individual boat. National letters may be added and shall be displayed on the mainsail above the sail numbers and below the class insignia. Changes RRS Appendix G.
- a) Sail numbers shall be no less than 10 in. (25.4 cm) in height. This changes RRS Appendix G 1.2 (b).
- b) Sail numbers shall be distinguishable on both sides of the sail.
- 12.5 All mainsails shall bear the Hobie "H" registered trademark logo, which is the class insignia.
- 12.6 Friction reducing devices may be applied to, or attached to, the luff rope to help with raising and lowering the sail.
- 12.7 Any grommet on a Hobie sail may be replaced as long as it is with an equal size or larger grommet located within 3 in. (7.6 cm) of the original location.
- 12.8 Reefing is permitted and may be rigged in any manner except in the North American Region where the mainsail wire halyard shall not extend below the COMPTIP.
- 12.9 Sail numbers consecutively assigned by Hobie Cat Company may be one to six digits in length. Letters and numbers are not required on headsails and spinnakers but when used shall be the same number as on the mainsail. This changes RRS Appendix G.
- 13. MASTS**
- 13.1 The section of the mast extrusion shall not be altered in any way except as provided for in 13.4.
- 13.2 No internal devices are allowed except as supplied.
- 13.3 A COMPTIP shall be mandatory for the South American Region (except Argentina, Uruguay and Brazil) and the North American Region with

the exception of the Hobie Tiger, Hobie Dragoon, Hobie FX-One and Hobie Fox, which shall be raced worldwide with an aluminium mast. All sailors will be allowed one exemption to this rule. After the one exemption is granted, the onus is on the individual to prove that an attempt has been made to obtain a COMPTIP. In the case of factory back orders on COMPTIPs, temporary exemption will be granted upon proof of such back order and only until back order is filled. COMPTIP and aluminium masts shall be legal in the North Pacific and International Regions. All aluminium masts are mandatory in the South Pacific, Southern Africa, European Regions and Argentina, Uruguay and Brazil with the exception of the H-17 in Europe where COMPTIP and ALUMINIUM masts are legal for H-17 boats manufactured before 1 January 1995 and Hobie 17 COMPTIP masts shall be mandatory in the South Pacific Region. Hobie 18 all aluminium masts shall be mandatory in the South Pacific Region. Hobie Dragons built in 2003 and prior (as engraved on the Hobie Cat Co. plaque affixed on the rear beam) may continue to use the COMPTIP when racing in North American Region.

14. BOOMS

- 14.1 The section of the boom extrusion shall not be altered in any way.
- 14.2 Boom bales for the purpose of hanging mainsheet blocks may be added, deleted or relocated.
- 14.3 No internal devices are allowed except as supplied.

15. WIRES

- 15.1 Wires as supplied by the HOBIE CAT CO. shall not be reduced in diameter. They may be increased in size. All wires may be shortened or lengthened with exception of bridle wires.
- 15.2 Shrouds and forestays shall connect to the HOBIE CAT CO. supplied shroud adjusters. The twist toggle shall not be removed and must be used as supplied.
- 15.3 An additional shroud adjuster may be added to the forestay in lieu of changing wire length.
- 15.4 The clevis pin and ring on the forestay adjuster, as provided by the HOBIE CAT CO., may be replaced by a quick-release pin, shackle or like equipment.

16. EQUIPMENT

- 16.1 A single boom vang may be added. It may be attached to the base of the mast and/or be movable from side to side on the front crossbar for use as a preventer. Vangs shall not travel on tracks or wires, which can be fastened to both sides of the boat simultaneously. The maximum purchase shall not exceed 3:1.
- 16.2 Sheets and lines:
 - a) Any diameter and quality of sheets and lines may be used unless prescribed otherwise in these rules or in the individual boat class rules.
 - b) Any sheet or lines made in whole or part of wire are prohibited, except as supplied by the HOBIE CAT CO. Sheets and lines, with the exception of the spinnaker halyard systems, are not permitted to be tapered unless allowed in the individual boat Class Rules.
- 16.3 Compasses with brackets or electronic devices that provide timing and heading memory but which do not transmit, transfer or receive data are permitted. The use of navigation and speed metering equipment is illegal unless specifically allowed in the individual boat rules or by the Notice of Race for the particular event or regatta. Radios may be used for weather information and for emergencies under the following conditions: On board radios shall be turned OFF and stored from 1/2 hour prior to the boat's Class warning signal of the first race of the day until after the finish of the last race of the day unless there is an emergency, or unless specified otherwise in the Notice of Race and Sailing Instructions.

If an on board radio is turned ON to any channel during the time restriction in 16.3 a) other than for an emergency, the competitor shall retire immediately and notify the race committee of its action. Improper use of an on board radio is a protestable action under Fair Sailing RRS 2 and may result in disqualification from the race or entire series.
- 16.4 Main, boom and jib sheet blocks of different design or make may be used provided the purchase advantage remains equal to or less than 7:1 on the mainsheet system and 3:1 on the jib sheet system unless specified otherwise in individual boat class rules.
- 16.5 Mesh and canvas trampolines manufactured by the HOBIE CAT CO. are class legal.
 - a) Trampolines may be reversed end for end if desired.

- b) Storage pockets and flaps to prevent water spray may be added.
 - c) A second set of hiking straps may be installed and altered as desired.
 - d) Hiking straps shall not be adjustable while on the water.
 - e) A trampoline may be comprised of one to three pieces.
- 16.6 Tools and personal convenience accessories may be carried on board and may include: tell-tales; toolkits; non-skid; wind indicators; stow bags; beverage coolers; food and beverages; etc. If in doubt on any item not listed, refer to General Class Rule 4.
- 16.7 Epoxy adhesive may be applied to the frame castings for the purpose of stiffening the boat.
- 16.8 No swivel connectors are allowed unless supplied as original equipment or allowed in the individual boat Class Rules.
- 17. CREW AND CREW WEIGHT**
(Where Class Rules require a minimum weight)
- 17.1 The word "crew" includes all personnel aboard the boat.
- 17.2 The same crew shall be used throughout the race or regatta. Crew shall not be added or removed without prior written permission from the race committee.
- 17.3 If a crew change is required due to injury or other special circumstances, the crew weight shall not be less than the original weight and not more than 10 lbs. (4.54 kg.) over the original weight unless approved by the race committee.
- * Weights may be carried to maintain the original crew weight provided the provisions of Rule 17.4 are met.*
- 17.4 A maximum of 50 lbs. (22.7 kg.) of permanent dry (solid) weight may be carried on the boat to bring crew weight up to the minimum.
- a) Weights may be moveable but shall be attached to the boat. This changes RRS 51.
 - b) If more than 50 lbs. (22.7 kg) are needed to make minimum weight, an additional crew person shall be carried.
- 17.5 Minimum crew weights are based on the body weight of the crew dressed in lightweight clothing without shoes.
- a) Light weight clothing is defined as swimwear or t-shirt (or similar) and shorts.
 - b) The crew shall maintain minimum crew weight at all times. If required, the crew may have to add weight during a regatta to maintain minimum crew weight.
 - c) Boats and or/crew can be protested at any time during the regatta for minimum weight infractions.
- 17.6 Weights required to meet minimum crew weight shall not be usable for any other purpose.
- 17.7 For the purpose of Youth and/or Junior Events, the following apply unless otherwise prescribed in the Notice of Race or Sailing Instructions:
- a) Competitors for Youth series shall be under the age of 21 years of age on 31 December of the year of the event.
 - b) Competitors for Junior series shall be under the age of 16 years of age on 31 December of the year of the event.
 - c) For ISAF Events and qualification series up to ISAF Events (or events using the ISAF age definition) all competitors shall be under the age of 19 years on 31 December of the year of the event.
- 17.8 For the purpose of Master and/or Grand Master Events following apply:
- a) The helmsperson for Master series shall be 45 years or older on 31 December of the year of the event. The age of crew members in Master series is open.
 - b) The helmsperson for Grand Master series shall be 55 years or older on 31 December of the year of the event. The age of crew members in Grand Master series shall not be less than 40 years on 31 December of the year of the event.
- 18. PERSONAL BALLASTS, CLOTHING AND EQUIPMENT**
- 18.1 The IHCA permits a maximum 22.0 lbs. (10 kg) of wet clothing and equipment per crew member to be worn. This changes RRS 43.1(b).
- a) Any competitor wearing such personal ballast is required to also wear a personal flotation device capable of flotation of both the wearer and the wet clothing and equipment.

- b) Weight and water jackets for the purpose of adding personal ballast are not permitted, shall not be considered clothing or equipment, and shall not be allowed for meeting minimum crew weight.

18.2 Any clothing or equipment worn under Rule 18.1 shall not be allowed for meeting minimum crew weight.

19. MINIMUM BOAT WEIGHTS

19.1 The minimum boat weights shown in the individual Class Rules are for each class of boat, ready to sail, with all permanently attached and non movable racing equipment EXCLUDING the following:

- a) Cushions
- b) Life jackets
- c) Trapeze harnesses
- d) Tool bags
- e) Personal gear
- f) Crew weight

19.2 All weights required to bring a boat to minimum weight shall be permanently attached during a regatta and shall not be usable for any other purpose.

20. ADVERTISING

20.1 Advertising is allowed in accordance with RRS 79 and ISAF Advertising Code, Category C, unless the Notice of Race and Sailing Instructions designate otherwise.

20.2 In world and continental events a competitor shall be required to display advertising in accordance with RRS Appendix 1, the Notice of Race, and the Sailing Instructions.

ALTERNATIVE PENALTIES FOR RRS PART 2 RULE INFRINGEMENTS

21. IHCA 360-DEGREE RULE

(This modifies RRS 44.1 and 44.2.)

21.1 The 720-degree Turns Penalty in RRS 44.1 and 44.2 is replaced by a 360-degree Turns Penalty. Changes RRS 44.1 and 44.2

- a) A 360-degree Turns Penalty consists of one tack and one gybe, or one gybe and one tack, before resuming course.

21.2 When neither boat acknowledges fault, a protest may be lodged in accordance with RRS Part 5 and the sailing instructions.

21.3 The protest time limit to file a protest will be (determined by local conditions) after the last boat

in the last race of the day sailing directly to shore reaches the shore. Changes RRS 61.3.

22. SCORING, PENALTIES AND PENALTY SCORING

22.1 Scoring, penalties, and penalty scoring are as described in the RRS unless changed in the Notice of Race and Sailing Instructions.

22.2 All boat, crew weight, and equipment violations are scored DNE – Disqualified Not Excludable under RRS 89.3(b). Whenever possible, competitors should be warned of potential equipment violations on the beach before racing when observed by other competitors, the jury, or regatta officials.

23. JURISDICTION OF RULES

All regattas held within regions under the jurisdiction of the IHCA shall be governed by: the RRS; these IHCA Rules; the prescriptions of the National Sailing Authority having jurisdiction where they apply; the Notice of Race; the event Sailing Instructions.

24. SIGNALING A PROTEST

A boat protesting another boat shall follow RRS 61.1(a) with the following modification: The ISAF requirement for under 6 meter boats applies to all Hobie Catamaran Classes.

25. RULE INTERPRETATIONS

Valid questions regarding the design or the specifications of the boats and these rules may be ruled on an interim basis by the IHCA Rules Committee Chair or the IHCA Rules Committee Chair designee.

Interim rulings, as needed, shall be accepted, rejected or modified by the IHCA Rules Committee and ratified by the IHCA International Council and approved by the ISAF before achieving permanent status in the IHCA Class Rules.

26. RULE AMENDMENTS

26.1 Suggestions, recommendations or requests for changes to design or specifications of the boats, rule additions, deletions or amendments, shall be submitted in writing to the IHCA Rules Committee. The proposals will be reviewed by the Rules Committee, and if found to have merit, be distributed for comment to: Hobie Cat sailors; IHCA International Council members; IHCA Regional Associations; and other interested parties. Following the comment period the IHCA Rules Committee will make a rule recommendation and submit it to the IHCA International Council for consideration. The Council shall accept or reject the Rules Committee re-

commendation and submit IHCA approved changes to the ISAF for approval. Interim or emergency rulings made by the Rules Committee Chair or Rules Committee as a whole will use the same approval procedure as outlined herein before they receive approved rule status.

26.2 Any proposed changes to design or specifications of the boats, new class rules, rule changes or amendments requesting comments, and all new rules and interpretations shall be announced in one or more of the following ways:

- a) An international mailing or individual Email to all IHCA members for General Rule changes, or international mailings or individual Email to individual boat class owners for rules only impacting the individual class.
- b) Prominent display on the IHCA web page requesting comment from Hobie Cat sailors and other interested parties.

27. DISCLAIMER OF LIABILITY

Competitors participate in regattas entirely at their own risk. The International Hobie Class Association will not accept any liability for material damage or personal injury or death sustained in conjunction with or before, during, or after a regatta.

28. MEMBERSHIP

At least one crew member on board a competing boat shall be a member in good standing of the International Hobie Class Association in accordance with the constitution of the International Hobie Class Association at world, regional and national championships unless prescribed otherwise in notice of race.

HOBIE DRAGOON CLASS RULES

NOTE: THE HOBIE CLASS GENERAL RULES ARE PART OF THESE RULES.

1. RUDDER BLADES, RUDDER ASSEMBLIES AND DAGGERBOARDS

- 1.1 Rudder blades and rudder assemblies shall be stock as supplied by the HOBIE CAT CO.
- 1.2 HOBIE CAT CO. supplied rudder assemblies and rudder blades shall not be modified except for minimum filing to improve fit and function.

2. HULLS AND DECKS

No changes may be made to the hulls that decrease weight or hull strength by removing flotation or standard factory fibreglass reinforced plastic (FRP) lay-up.

3. SAILS

- 3.1 Mainsail downhaul purchase shall not exceed 6:1 and may be rigged in any manner.
- 3.2 Jib sail downhaul purchase shall not exceed 3:1 and may be rigged in any manner.
- 3.3 Reefing of any sail is permitted. Reefing design shall be open provided it does not structurally weaken the boat or interfere with basic functions of HOBIE CAT CO. supplied components.
- 3.4 Pig Tails for the purpose of attaching blocks may be added to the clew of the jib.
- 3.5 Adjustable rope luff and leech lines may be installed within existing luff and leech tapes on spinnakers.

4. MASTS

- 4.1 The mast design shall not be altered in any way except for the attachment of fittings and equipment for flying open class third sails or reefing.
- 4.2 No internal devices are allowed except as supplied.
- 4.3 A preventer, or otherwise known as a positive mast rotator, may be added to keep the mast in rotation, and may be rigged in any manner.
- 4.4 Additional mast rotation devices and related control equipment may be installed. Design shall be left open provided it does not structurally weaken the boat.
- 4.5 The black band (top) shall be located 38 cm (14.96 inches) from the bottom of the mast extrusion to the top of the black band.

- 4.6 The head of the spinnaker shall not be hoisted higher than 5420 mm (213,386 inches) from the base of the extrusion. At the halyard block or keeper the bearing surface of the halyard shall be no more than 70 mm (2,756 inches) from the surface of the mast. For the purposes of measurement, the halyard shall be pulled tight to the tack fitting.

5. WIRES AND RUNNING GEAR

- 5.1 Running gear of any type may be used provided it is of equal strength or better than HOBIE CAT CO. supplied equivalent components. Tapered sheets are not allowed.
- 5.2 Additional shroud adjusters may be added to the forestay bridle.
- 5.3 Bridle wire lengths shall not be shorter than 101 cm (39,76 inches) and shall attach to the jib furler as supplied.

6. EQUIPMENT

- 6.1 Additional safety equipment of any type is permitted.
- 6.2 Mainsheet blocks of different design or make may be used, provided the purchase advantage is equal to or less than 6:1.
- 6.3 The mainsheet system shall be of a conventional type with the lower block(s) attaching to the traveller car and the upper block(s) attaching to the boom or the mainsail clew. A wire strop to attach the upper block to the boom or the mainsail clew is permitted.
- 6.4 Jib sheet blocks of different design or make may be used provided the purchase advantage is equal to or less than 3:1. Jib cleats may be moved. Self-tacking jib system* as supplied by Hobie Cat Co. is permitted. Sheets and lines related to the self-tacker may be rigged in any manner.
** Defined as track (including its support posts and attachment fittings) and car.*
- 6.5 Replacement blocks or fittings shall not be constructed of exotic materials such as carbon, titanium, etc.
- 6.6 Spinnaker sheet blocks of different design or make may be used. Additional blocks may be added. The spinnaker sheet blocks and spinnaker

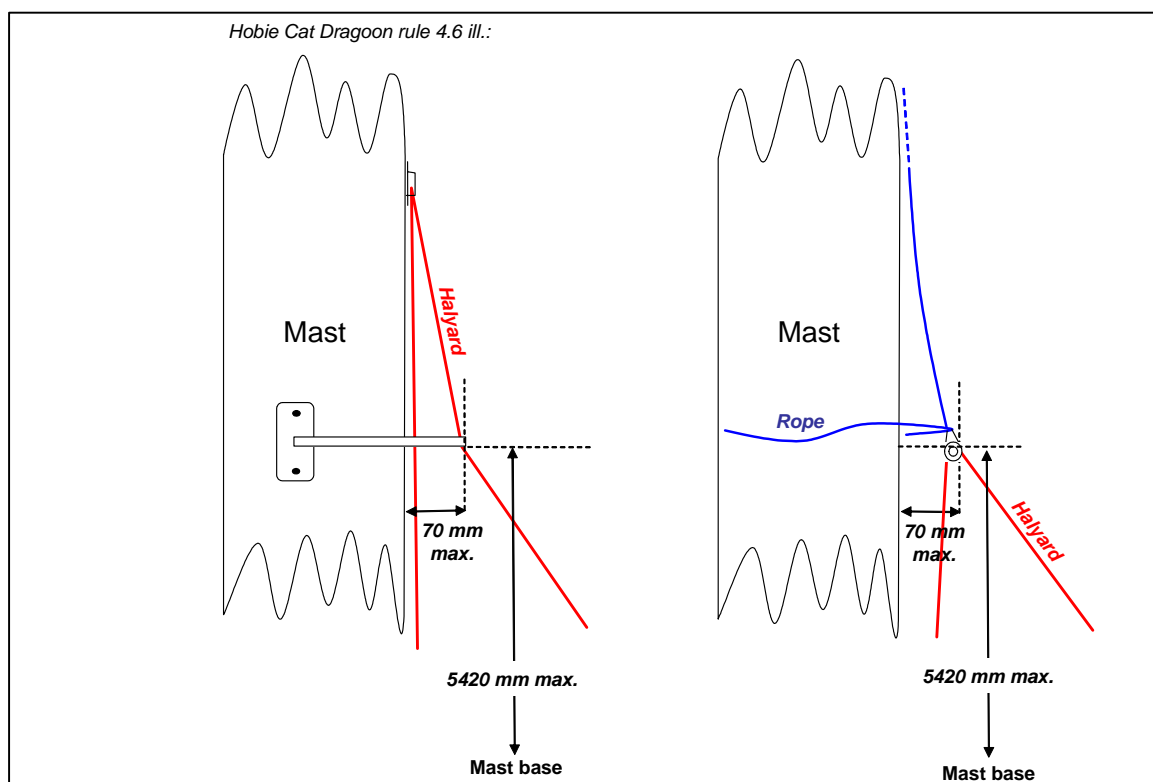

ker running gear may be mounted/rigged in any manner. The addition of snuffer type retrievable systems of any design; including wind-up/dog leash retrievable halyard systems are allowed. Carbon fibre material is not permitted in the snuffer.

- 6.7 Hiking straps and foot straps may be added.
- 6.8 Additional grommets may be added to the trampoline.
- 6.9 Crossbars and decks may be coated to improve footing.
- 6.10 Line(s) or elastic cord(s) may be added as tangle preventers for jib sheet lines, spinnaker and spinnaker sheet/halyard lines
- 6.11 Safety lines are permitted.
- 6.12 Tapered sheets, lines and halyards for the spinnaker are permitted.

7. SAFETY EQUIPMENT

Maximum extension of shroud lengthening devices are 68.6 cm (27 inches) The shroud lengthening device must be returned to its normal storage position after use and before continuing to race. See Rule # 8 of the General Rules.

8. MINIMUM CREW WEIGHT

The Hobie Dragoon shall have a minimum combined crew weight of 90 kg. (198 lbs.)

9. MINIMUM BOAT WEIGHTS

The minimum weight of a Hobie Dragoon completely assembled with spinnaker and running gear shall 100 kg. (220.5 lbs.) See Rule #19 of the General Rules.

10. TRAPEZES

A maximum of two trapeze wires are allowed on each side of the boat.

- 10.1 Trapeze wires may be shortened, lengthened and have adjustable systems installed.
- 10.2 Trapeze shock cords may lead from different fairleads than those supplied by the HOBIE CAT CO.

11. THIRD SAIL (SPINNAKER) AND SPINNAKER POLE (BOWSPRIT)

- 11.1 The Hobie Dragoon class spinnaker of max. 10.31 m² (110.98 sq. ft) as supplied by the HOBIE CAT CO. shall be carried during Class events.
- 11.2 Only bowsprits supplied by a HOBIE CAT COMPANY are class legal. The bowsprit shall be fixed on the longitudinal centre line of the boat as provided by the manufacturer. Supporting wires/lines may be shortened, lengthened, mounted and/or rigged in any manner. Additional blocks/cleats for spinnaker running gear and jib luff control as well as snuffer type systems may be mounted on the bowsprit.

HOBIE WAVE CLASS RULES

NOTE: THE HOBIE CLASS GENERAL RULES ARE PART OF THESE RULES.

1. RUDDER BLADES AND RUDDER ASSEMBLIES

- 1.1 Rudder blades and rudder assemblies shall be stock as supplied by the HOBIE CAT CO.
- 1.2 HOBIE CAT CO. supplied rudder assemblies and rudder blades shall not be modified except for minimum filing to improve fit and function.

2. HULLS

No changes may be made to the hulls that decrease weight or hull strength by removing material from either the outside skin or the internal foam layer.

3. SAILS

- 3.1 Mainsail downhaul purchase shall not exceed 3:1 and may be rigged in any manner.
- 3.2 Reefing of any sail is permitted. Reefing design shall be open provided it does not structurally weaken the boat or interfere with basic functions of HOBIE CAT CO. supplied components.

4. MASTS

- 4.1 The mast design shall not be altered in any way.
- 4.2 No internal devices are allowed except as supplied.
- 4.3 The black band shall be located 16.63 inches (42.23 cm) from the bottom of the mast extrusion to the top of the black band.

5. WIRES AND RUNNING GEAR

- 5.1 Running gear of any type may be used provided it is of equal strength, or better than HOBIE CAT CO. supplied equivalent components. Tapered sheets are not allowed.
- 5.2 Additional shroud adjusters may be added to the forestay bridle.
- 5.3 The clevis pin and ring on the forestay and/or shroud adjuster, as provided by HOBIE CAT CO., may be replaced by a quick-release pin or shackle.

6. EQUIPMENT

- 6.1 Two inspection ports per deck may be added to the boat
- 6.2 Additional safety equipment of any type is permitted.
- 6.3 Mainsheet blocks of different design or make may be used, provided the purchase advantage is equal to or less than 4:1.
- 6.4 The mainsheet system shall be of a conventional type with the lower block(s) attaching to the rear crossbar and the upper block(s) attaching to the clew of the sail.
- 6.5 Replacement blocks or fittings shall not be constructed of exotic materials such as carbon, titanium, etc.
- 6.6 Hiking straps and foot straps may be added.
- 6.7 Additional grommets may be added to the trampoline.
- 6.8 Crossbars and decks may be coated to improve footing.
- 6.9 Safety lines are permitted.

7. SAFETY EQUIPMENT

- 7.1 A minimum 3/8 inches (9.5 mm) diameter righting line consisting of at least one 14 ft. (4.27 meter) length of line or two 7 ft. (2.13 meter) lengths of line minimum shall be securely attached and readily accessible from each side of the boat. The righting lines shall be in addition to all other required equipment. This rule modifies general rule 8.2
- 7.2 A mast float, as provided standard with the boat by the HOBIE CAT CO. shall be attached to the mast head while racing.

8. MINIMUM CREW WEIGHT

The Hobie Wave shall have a minimum crew weight of 120 lbs. (54.43 kg)

9. MINIMUM BOAT WEIGHTS

The minimum weight of a Hobie Wave completely assembled all running gear shall be 251 lbs. (114 kg.) See Rule #19 of the General Rules.

HOBIE 14 CLASSIC / 14 TURBO CLASS RULES

NOTE: THE HOBIE CLASS GENERAL RULES ARE PART OF THESE RULES.

HOBIE 14 CLASSIC:

1. RUDDERS AND RUDDER ASSEMBLIES

1.1 Rudder blades made of another material yet conforming with the size, shape and minimum weight of the standard rudder blades may be used. Rudder blades must conform within the minimum and maximum dimensions that are found within the profile plans. Profile plans are available through the IHCA.

1.2 The maximum thickness of a rudder blade(s) shall not exceed 1.015 in. (25.8 mm.), tapering over a distance of 2 ft. (60.96 cm) to a maximum thickness of 1/2 in. (12.7 mm), 2 in. (50.8 mm) from the bottom tip of the rudder. These dimensions are for reference purposes only. Please refer to profile plans for exact dimensions. Profile plans are available through the IHCA.

2. TRAVELLERS AND TRAVELLER CARS

2.1 Any type traveller cars that operate in the HOBIE CAT CO. supplied traveller tracks are acceptable. The tracks shall not be altered, changed or added to in any way.

2.2 The location and type of traveller cleat may be altered provided it remains attached to the rear crossbar.

2.3 The HOBIE CAT CO. supplied integrated traveller systems are class legal.

3. MASTS

3.1 A pad eye and single cleat of your choice may be added to either side of the mast for Cunningham adjustment consisting of one line equalling not more than a 2:1 purchase.

3.2 Each mast shall have a black band around it, as supplied by the HOBIE CAT CO. to indicate maximum downhaul.

a) The top of the black band is located 20 ft. 7-1/2 in. (6.29 meters) from the top of the mast not including the mast cap.

b) The uppermost portion of the gooseneck slide shall be the guide for measurement, and the top of the slide must not be down-hauled beyond the top of the band.

3.3 Minimum filing or cutting to the mast step casting is permitted for the purpose of improving rotation. Stops may be added to replace the standard mast stops. Stops may be added to replace the standard mast stops. The mast step casting stops may be removed completely provided a mast rotation control kit is being used under provision of Rule # 3.5 of these rules. *(Interim ruling until approved by ISAF)*

3.4 The mast base casting rotation stops may be altered, but the casting rotation stops shall not be removed, and the mast shall remain free to rotate from side to side. The mast shall not have controls to permit adjustments while racing, except as outlined in Rule # 3.5 of these rules and Rule #16.1 of the General Rules.

3.5 A mast rotation control kit as supplied by HOBIE CAT CO may be mounted. The mast rotation control purchase shall not be greater than 2:1 and the mast rotation kit shall not have controls to permit adjustments while on trapeze.

4. WIRES

4.1 Shroud chain plates may be shifted a maximum of 1 in. (25.4 mm) fore or aft.

4.2 Bridle length shall not be shorter than 60-7/8 in. (154.62 cm) pin to pin.

5. EQUIPMENT

5.1 All downhaul systems allowed prior to the upgrade effective April 1st 2005 will remain class legal.

a) The upgraded downhaul system shall be as supplied by HOBIE CAT CO and shall not exceed 6:1 purchase.

b) Blocks and cleats on the upgraded system may be replaced with similar types provided the custom attachments to the mast base and gooseneck supplied by HOBIE CAT CO are used.

c) Swivel cam cleats are not allowed. The upgraded downhaul design has some limited movement from side to side. Any replacement cams may not exceed the side to side movement of the HOBIE CAT CO supplied system.

- 5.2 The outhaul purchase shall not exceed 2:1. No internal outhaul devices are allowed. The outhaul system may be changed to the owner's and skipper's specification provided the outhaul line runs over the end cap of the boom. Optional friction reducing end caps supplied by HOBIE CAT CO. are permitted. Such end caps may have sheaves built in. Inhaul systems are not allowed.
- 5.3 The outhaul line may be changed at the sail clew, provided it runs over the end of the boom to the cleat. The mechanical purchase of the outhaul shall not be altered from 1:1.
- 5.4 A single line or shock cord line may be secured to the bridle intersection and run to a cleat on the front crossbar to adjust mast rake. The mechanical purchase shall not exceed 1:1.
- 5.5 A clew keeper line may be tied through the clew of the mainsail to the boom. Blocks or cleats shall not be used. Slugs (maximum of two), that fit into the boom track, may be attached to the clew of the main instead of the clew keeper.
- 5.6 A single trapeze may be used during Class competition. Wire length is optional. Adjustable systems are optional.
- 5.7 A dolphin striker assembly may be added to the front crossbar.
- 5.8 Two inspection ports per deck may be added to the boat.
- 6. MINIMUM CREW WEIGHT**
No minimum.
- 7. MINIMUM BOAT WEIGHT**
The minimum boat weight of a Hobie 14, completely assembled, shall be 240 lbs. (109 kg.). (See Rule #19 of the General Rules.)
- 8. HOBIE 14 TURBO:**
The Hobie 14 Turbo Class Rules are the same as the Hobie 14 Classic Class Rules, except as modified herein.
- 9. EQUIPMENT**
- 9.1 A single trapeze may be used during Class competition. Wire length is optional. Adjustable systems are optional.
- 9.2 A dolphin striker shall be added to the front crossbar.
- 9.3 Foot straps may be installed on the sidebars or hulls.
- 9.4 The jib and jib assembly must be HOBIE CAT CO. supplied and installed to HOBIE CAT CO. specifications.
- 9.5 Sidebars, crossbars and decks may be coated to improve footing.
- 9.6 Safety lines are permitted.
- 9.7 The pin connecting the jib tack to the furler shall not be lower than 0.76 meters (29,92 inches) measured from an imaginary line from across the top of the decks right behind the bow tangs.
- 10. MINIMUM CREW WEIGHT**
150 lbs. (68.1 kg.)

HOBIE 16 CLASS RULES

NOTE: THE HOBIE CLASS GENERAL RULES ARE PART OF THESE RULES.

1. RUDDERS AND RUDDER ASSEMBLIES

- 1.1 Rudder blades made of another material, yet conforming to the size, shape and minimum weight of the standard rudder blades, may be used. Rudder blades must conform within the minimum and maximum dimensions that are found within the profile plans. Profile plans are available through the IHCA.
- 1.2 The maximum thickness of a rudder blade(s) shall not exceed 1.015 in. (25.8 mm.), tapering over a distance of 2 ft. (60.96 cm) to a maximum thickness of 1/2 in. (12.7 mm), 2 in. (50.8 mm) from the bottom tip of the rudder. These dimensions are for reference purposes only. Please refer to profile plans for exact dimensions. Profile plans are available through the IHCA.

2. TRAVELLERS AND TRAVELLER CARS

- 2.1 Any type of traveller cars that operate in the HOBIE CAT CO. supplied traveller tracks are acceptable. The tracks shall not be altered, changed or added to in any way.
- 2.2 The location and type of main and jib traveller cleats may be altered, provided they remain attached to their respective crossbars.
- 2.3 Jib traveller cars may be moved and relocated in the jib traveller tracks as desired, provided cleats, swivels or stops are attached to the front crossbar. The jib sheet block shall not be relocated from the track.
- 2.4 The HOBIE CAT CO. supplied integrated traveller systems are class legal.

3. MAIN AND JIB SAILS

- 3.1 A jib clew plate, measuring not more than 8 in. (20.32 cm) at its longest point and containing not more than five adjustment holes, may be added to the jib.
 - a) A maximum of 1-1/2 in. (38.1 mm) of sail, measured diagonally, may be removed from the jib for installation of the clew plate.
 - b) A grommet, measuring not more than 1-1/2 in. (38.1 mm) at the inside diameter, may be placed at the clew of the jib in place of the jib plate.

- 3.2 Jib batten pockets or velcro type systems may be installed in the Hobie 16 jib leech to eliminate the need for batten ties.
- 3.3 DACRON sails built from IHCA approved patterns and manufactured by the HOBIE CAT CO. are class legal.
- 3.4 Mylar sails built from IHCA approved patterns and manufactured by the HOBIE CAT CO. are class legal in the North American Region only. Mylar sails shall not be class legal for any international events.
- 3.5 The jib luff tension shall not be adjustable at the sail tack while sailing.

4. MASTS

Hobie Cat 16 rule 4.1 ill.:

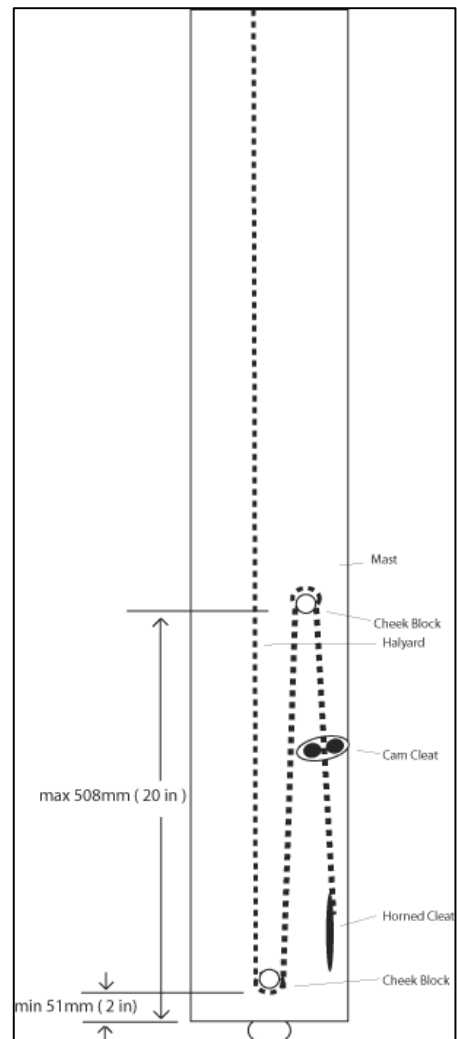

- 4.1 The standard 3:1 jib halyard downhaul system may be relocated if desired.
- a) A 3:1 maximum purchase pulley system installed at the head of the jib may replace the pigtail and standard jib downhaul system.
 - b) The cleat must remain on the mast with the jib halyard running down the mast and attached to the cleat while sailing.
 - c) Jib halyard tension may be adjusted while sailing.
 - d) The jib halyard can be cleated to both cleats on the mast to pull the halyard to the centre of the mast.
 - e) A cheek block may be added or moved to the centre of the mast to guide the halyard to the front centre of the mast. The block shall in this case be located maximum 51 mm (2 in.) above the base of the mast extrusion using this and the lowest bearing surface of the block as measurement points.
 - f) An additional cheek block may be added to guide the halyard from the centre cheek block to a horned keeper cleat. This block shall be located maximum 508 mm (20 in.) above the base of the mast extrusion using this and the highest bearing surface of the block as measurement points.
 - g) A surface mounted cam cleat may be added in front of the horned keeper cleat to make it easier to adjust the halyard. The cam cleat may be mounted at any angle but must be surface mounted and may not swivel from side to side.
 - h) To gain friction the jib halyard may run through the mounted cheek blocks several times before going through the cam cleat.
 - i) When the halyard is not being adjusted the halyard may run through the cam cleat but shall be tied off to the horned keeper cleat.
 - j) Purchase for the jib halyard shall either be at the mast base or between the jib head and mast tang. If purchase is at the base it shall not exceed 5:1 and the halyard shall be wire.
- 4.2 Halyard clips for the purpose of moving the halyard aft of the mast are permitted. The halyard must still cleat to the original cleat on the mast.
- 4.3 A pad eye and single cleat of your choice may be added to either side of the mast for Cunning-

ham adjustment, consisting of one line equalling not more than a 2:1 purchase.

- 4.4 Each mast shall have a black band around it, as supplied by the HOBIE CAT CO., to indicate maximum downhaul.
- a) The black band is located 24 ft. 8 in. (7.52 meters) from the top of the mast not including the mast cap.
 - b) The uppermost portion of the gooseneck slide shall be the guide for measurement, and the top of the slide must not be downhauled beyond the top of the band.
- 4.5 Minimum filing or cutting to the mast step casting is permitted for the purpose of improving rotation, but metal shall not be removed for the purpose of achieving mast rake. Stops may be added to replace the standard mast stops but shall not be adjustable.
- 4.6 The mast base casting rotation stops may be altered, but the casting rotation stops shall not be removed, and the mast shall remain free to rotate from side to side. The mast shall not have controls to permit adjustments while racing, except as outlined in Rule #16.1 of the General Rules or as described in these boat class rules.

5. WIRES

- 5.1 Bridle lengths shall not be shorter than 44 in. (111.8 cm) pin to pin.
- 5.2 Pigtails may be changed or altered to increase strength only. They must connect at the mast tang and the jib halyard block in the same manner as the HOBIE CAT CO. supplied boat (except when the jib halyard is modified according to 4.1a).

6. EQUIPMENT

- 6.1 All downhaul systems allowed prior to the upgrade effective April 1st 2005 will remain class legal.
- a) The upgraded downhaul system shall be as supplied by HOBIE CAT CO and shall not exceed 6:1 purchase.
 - b) Blocks and cleats on the upgraded system may be replaced with similar types provided the custom attachments to the mast base and gooseneck supplied by HOBIE CAT CO are used.

- c) Swivel cam cleats are not allowed. The upgraded downhaul design has some limited movement from side to side. Any replacement cams may not exceed the side to side movement of the HOBIE CAT CO supplied system.
- 6.2 The outhaul purchase shall not exceed 2:1. No internal outhaul devices are allowed. The outhaul system may be changed to the owner's and skipper's specification provided the outhaul line runs over the end cap of the boom. Optional friction reducing end caps supplied by HOBIE CAT CO. are permitted. Such end caps may have sheaves built in. Inhaul systems are not allowed.
 - 6.3 A clew keeper line may be tied through the clew of the mainsail to the boom. Blocks or cleats shall not be used. Slugs (maximum of two) that fit into the boom track may be attached to the clew of the main instead of the clew keeper.
 - 6.4 The dolphin striker provided by the HOBIE CAT CO. shall not be removed.
 - 6.5 Two inspection ports per deck may be added to the boat.
 - 6.6 A swivel connector may be installed at the lower end of the pigtail of the jib forestay.
 - 6.7 Foot straps may be installed on the crossbars, sidebars or hulls.
 - 6.8 Sidebars, crossbars and decks may be coated to improve footing.
 - 6.9 Safety lines are permitted.
- 7. MINIMUM CREW WEIGHT**
- 7.1 The minimum combined crew weight of a Hobie 16 shall be 285 lbs. (129.3 kg.). (See Rule #17 of the General Rules.)
 - 7.2 The minimum combined women's crew weight for women's class racing events (non-open events) shall be 260 lbs (118.2 kg.)
 - 7.3 For the purpose of Youth Events, the minimum weight shall be 250 lbs (112.5 kg).
- 8. MINIMUM BOAT WEIGHT**
- The minimum weight of a Hobie 16, completely assembled, shall be 320 lbs (145.15 kg.). (See Rule #19 of the General Rules).
- 9. TRAPEZES**
- A maximum of two trapeze wires are allowed on each side of the boat. Supplied wires may be shortened, lengthened and have adjustable systems installed.

HOBIE 17 CLASS RULES

NOTE: THE HOBIE CLASS GENERAL RULES ARE PART OF THESE RULES.

1. RUDDER BLADES, RUDDER ASSEMBLIES AND CENTER BOARDS

- 1.1 The maximum length of the centerboard line is 12-1/2 in. (31.75 cm), measured from the top of the deck to the point of handle that cannot fit in the hole, in the fully up position.
- 1.2 Rudder blades, rudder assemblies and centerboards shall be stock as supplied by the HOBIE CAT CO. HOBIE CAT CO. supplied rudder housings and centerboards shall not be modified except for minimum filing to improve fit and function. Only HOBIE CAT CO. supplied after market rudders are allowed to replace stock rudders.
- 1.3 Anti-chafing and shimming pads may be added within max. 100 mm (3.93 in) from the front and rear edges of the centre board trunk to improve fit and reduce wear. Shims must not be used for the purpose canting the centre boards and shall be of equal thickness.

2. SAILS

Sail downhaul purchase shall not exceed 6:1. Downhaul must cleat on mast, boom or foot of sail and may be rigged in any manner. "Cam" Cleats are legal.

3. MASTS

Each mast shall have a black band around it as supplied by the HOBIE CAT CO. The black band shall be located between the rotation control and gooseneck 26 ft. 10 in. (8.18 m) from the top of the mast not including the mast cap. Boats manufactured after 1 January 1995 may only sail in European class competition with an all aluminium mast.

4. BOOMS

A shock cord may be installed to remove tension on the outhaul when the outhaul line is uncleated. The maximum purchase is 2:1.

5. WIRES

- 5.1 Bridle wire lengths shall not be shorter than 120 in. (3.05 meters) pin to pin.
- 5.2 Supplied trapeze wires may be shortened, lengthened and have adjustable systems installed. Only one trapeze wire per side is allowed.

6. EQUIPMENT

- 6.1 The Hobie 17 shall be raced with wings.
- 6.2 A preventer may be added to keep the mast in rotation and may be rigged in any manner.
- 6.3 Only HOBIE CAT CO. supplied trampolines and wing trampolines shall be used.
- 6.4 Hiking straps may be added to the trampoline or aluminium crossbars.
- 6.5 Foot straps may be added to the wings.
- 6.6 Righting water bags and/or shroud lengthening devices may be carried on board. The shroud-lengthening device must be returned to its normal storage position after use and before continuing to race. The maximum length of shroud lengthening devices shall be 26 in. (66.0 cm).
- 6.7 Two inspection ports per deck may be added to the boat.
- 6.8 Safety lines are permitted.

7. MINIMUM CREW WEIGHT

The minimum combined crew weight of a Hobie 17 shall be 160 lbs. (72.6 kg.). (See Rule 17 of the General Rules).

8. MINIMUM BOAT WEIGHT

The minimum boat weight of a Hobie 17 with wings, completely assembled, shall be 330 lbs (149.7 kg.) (See Rule #19 of the General Rules.)

9. TRAVELLERS AND TRAVELLER CARS

- 9.1 Any type of traveller cars that operate in the HOBIE CAT CO. supplied traveller tracks are acceptable. The tracks shall not be altered, changed or added to in any way.
- 9.2 The HOBIE CAT CO. supplied integrated traveller systems are class legal.

HOBIE FX-ONE CLASS RULES

NOTE: THE HOBIE CLASS GENERAL RULES WITH EXEPTION OF RULE 13.4 ARE PART OF THESE RULES.

1. RUDDER BLADES, RUDDER ASSEMBLIES AND DAGGERBOARDS

- 1.1. Rudder blades, rudder assemblies and dagger boards shall be stock as supplied by the HOBIE CAT CO.
- 1.2. Top edge of the dagger board in the down position shall not extend below the level of the deck into dagger board trunk.
- 1.3. Anti-chafing and shimming pads may be added to the dagger board trunk to improve fit and reduce wear. Shims must not be used to alter the angle of dagger boards.
- 1.4. HOBIE CAT CO. supplied rudder assemblies, rudder blades and dagger boards shall not be modified except for minimum filing to improve fit and function.

2. HULLS AND DECKS

No changes may be made to the hulls that decrease weight or hull strength by removing flotation or standard factory fibreglass reinforced plastic (FRP) lay-up. Minor fairing and repair to the hulls are allowed.

3. SAILS

- 3.1. Main sail 14,30 m² (153,92 sq. ft) and spinnaker 17 m² (182,99 sq. ft.) are to be raced as supplied from HOBIE CAT CO. Only main, and spinnaker sails built from HOBIE CAT CO. approved patterns and manufactured by or for HOBIE CAT CO. are class legal.
- 3.2. Any type of battens supplied by HOBIE CAT CO. is class legal. They may be cut, shaped and tapered as desired. Any type of batten caps may be used.
- 3.3. Mainsail downhaul purchase shall not exceed 16:1 and may be rigged in any manner.
- 3.4. Reefing of any sail is permitted. Reefing design shall be open provided it does not structurally weaken the boat or interfere with basic functions of HOBIE CAT CO. supplied components.
- 3.5. Pig Tails for the purpose of attaching blocks may be added to the clew.
- 3.6. A spinnaker sheet cleat may be added.

- 3.7. Adjustable rope luff and leech lines may be installed within existing luff and leech tapes on spinnakers.

4. MASTS

- 4.1. The mast design shall not be altered in any way except for the attachment of fittings and equipment for flying open class third sails or reefing.
- 4.2. No internal devices are allowed except as supplied.
- 4.3. A preventer, or otherwise known as a positive mast rotator, may be added to keep the mast in rotation, and may be rigged in any manner.
- 4.4. Additional mast rotation devices and related control equipment may be installed. Design shall be left open provided it does not structurally weaken the boat.
- 4.5. Spinnaker halyard rigging to be rigged with halyard going up through a turning block no higher than 6.775 meters (22.23 ft.) and then attaching to the spinnaker head.

5. WIRES AND RUNNING GEAR

- 5.1. Running gear of any type of stainless steel or rope may be used provided it is of equal strength or better than HOBIE CAT CO. supplied equivalent components. Tapered sheets are not allowed.
- 5.2. Additional shroud adjusters may be added to the forestay bridle.
- 5.3. The intersection of the bridle wires while rigged shall not be lower than 0.855 meters (33.66 inches) measured from an imaginary line from across the top of the decks right behind the bridle tangs.

6. EQUIPMENT

- 6.1. Additional safety equipment of any type is permitted.
- 6.2. Mainsheet blocks of different design or make may be used, provided the purchase advantage is equal to or less than 10:1.
- 6.3. The mainsheet system shall be of a conventional type with the lower block(s) attaching to the traveller car and the upper block(s) attaching to the boom. A strop to attach the upper block to

the boom is permitted.

- 6.4. Replacement blocks or fittings shall not be constructed of exotic materials such as carbon, titanium, etc.
- 6.5. Spinnaker sheet blocks of different design or make may be used. Additional blocks may be added. The spinnaker sheet blocks and spinnaker running gear may be mounted/rigged in any manner. The addition of snuffer type retrievable systems, including wind-up/dog leash retrievable halyard systems are allowed.
- 6.6. Hiking straps and foot straps may be added.
- 6.7. Additional grommets may be added to the trampoline.
- 6.8. Crossbars and decks may be coated to improve footing.
- 6.9. Line(s) or elastic cord(s) may be added as tangle preventers for spinnaker and spinnaker sheet/halyard lines.
- 6.10. Safety lines are permitted.
- 6.11. Wings as supplied by Hobie Cat Co. are permitted during racing. Overall beam not to exceed 3.76 meters (12.33 ft.)
- 6.12. Tapered sheets, lines and halyards for the spinnaker are permitted.

7. SAFETY EQUIPMENT

- 7.1. A minimum 9.5 mm (3/8 inches) diameter righting line consisting of at least one 4.9 meter (16 ft.) length of line or two 2.45 meter (8 ft.) lengths of line minimum shall be securely attached and readily accessible from each side of the boat. The righting lines shall be in addition to all other required equipment.
- 7.2. Righting water bags, righting pole type devices and shroud lengthening devices may be carried

on board. Maximum extension of shroud lengthening devices is 68.6 cm (27 inches). The shroud lengthening device must be returned to its normal storage position after use and before continuing to race.

8. MINIMUM CREW WEIGHT

The Hobie FX-ONE shall have a minimum combined crew weight of 72 kg (158.73 lbs.).

9. MINIMUM BOAT WEIGHTS

The minimum weight of a Hobie FX-ONE, completely assembled with spinnaker and running gear shall be 148.5 kg (327.39 lbs). See Rule #19 of the General Rules.

10. TRAPEZES

- 10.1. A maximum of one trapeze wire is allowed on each side of the boat.
- 10.2. Trapeze wires may be shortened, lengthened and have adjustable systems installed.
- 10.3. Trapeze shock cords may lead from different fairleads than those supplied by the HOBIE CAT CO.

11. SPINNAKER AND SPINNAKER POLE (BOWSPRIT)

- 11.1. The Hobie FX-ONE class spinnaker of 17 m² (182,99 sq. ft.) as supplied by the HOBIE CAT CO. shall be carried during Class events
- 11.2. Only bowsprits supplied by a HOBIE CAT CO are class legal. The bowsprit shall be fixed on the longitudinal centre line of the boat as provided by the manufacturer. Supporting wires/lines may be shortened, lengthened, mounted and/or rigged in any manner. Additional blocks/cleats for spinnaker running gear as well as snuffer type systems may be mounted on the bowsprit.

HOBIE 18 / HOBIE 18 MAGNUM / HOBIE SX-18 / HOBIE 18 FORMULA CLASS RULES

NOTE: THE HOBIE CLASS GENERAL RULES ARE PART OF THESE RULES.

1. RUDDER BLADES, RUDDER ASSEMBLIES AND DAGGER BOARDS

- 1.1 Rudder blades, rudder assemblies and dagger boards shall be stock as supplied by the HOBIE CAT CO. HOBIE CAT CO. supplied rudder housings and dagger boards shall not be modified except for minimum filing to improve fit and function. Only HOBIE CAT CO. supplied after-market rudders are allowed to replace stock rudders.
- 1.2 Dagger boards in the down position shall not extend into the dagger board trunk beyond one half the diameter of the rope handle hole.
- 1.3 Anti-chafing and shimming pads may be added to the dagger board trunk to improve fit and reduce wear. Shims must not be used to alter the angle of dagger boards.

2. SAILS

- 2.1 A reef point may be added to the mainsail.
- 2.2 A jib clew plate, measuring not more than 8 in. (20.32cm) at its longest point and containing not more than five adjustment holes, may be added to the jib.
 - a) A maximum of 1-1/2 in. (38.1 mm) of sail, measured diagonally, may be removed from the jib for installation of the clew plate.
 - b) A grommet measuring not more than 1-1/2 in. (38.1 mm) at the inside diameter may be placed at the clew of the jib in place of the jib clew plate.
- 2.3 Pig tails for the purpose of attaching blocks may be added to the clew of the jib and the boom bale

3. MASTS

Each mast shall have a black band around it, as supplied by the HOBIE CAT CO. The black band shall be located 27 ft. (8.23m) from the top of the mast not including the mast cap for the 18 and 18 Magnum.

4. WIRES

Bridle lengths shall not be shorter than 41 in. (104.14 cm) pin to pin.

5. EQUIPMENT

- 5.1 Sail downhaul purchase shall not exceed 8:1 purchase. Rigging of downhaul and related control equipment may be installed to the owner's and skipper's specification, provided it does not structurally weaken the mast or interfere with other HOBIE CAT CO. components. The downhaul attachment point to the sail shall remain in the same location as supplied by the HOBIE CAT CO.
- 5.2 Line(s) or bungee cord(s) may be added as a tangle preventer for jib sheet lines.
- 5.3 Foot straps may be installed on the hulls.
- 5.4 Crossbars and decks may be coated to improve footing.
- 5.5 Safety lines are permitted.
- 5.6 Additional mast rotation devices and related control equipment may be installed to the owner's and skipper's specification, provided it does not structurally weaken the mast or the boat or interfere with HOBIE CAT CO. components.
- 5.7 Additional jib cleats may be installed to the owner's and skipper's specifications provided their mounting does not structurally weaken the boat or interfere with other HOBIE CAT CO. components.

6. MINIMUM CREW WEIGHT

- 6.1 The minimum combined crew weight of a Hobie 18 shall be 295 lbs. (133.8 kg.) (See Rule No 17 of the General Rules.)
- 6.2 The minimum combined women's crew weight for women's class racing events (non-open events) shall be 260 lbs (118.2 kg.)

7. MINIMUM BOAT WEIGHT

The minimum weight of a Hobie 18, completely assembled, shall be 400 lbs. (181.4 kg). (See Rule #19 of the General Rules.)

8. TRAPEZES

A maximum of two trapeze wires are allowed on each side of the boat.

- a) Supplied wires may be shortened, lengthened and have adjustable systems installed.

- b) Trapeze shock cords may lead from different fairleads than those supplied by the HOBIE CAT CO. but shall lead through the hull flange.

9. HOBIE 18 MAGNUM

The Hobie 18 Magnum Class Rules are the same as the Hobie 18 Class Rules except as modified herein.

10. EQUIPMENT

- 10.1 The Hobie 18 Magnum shall be raced with wings supplied by the HOBIE CAT CO.
- 10.2 Hiking straps may be added to the crossbars or wing supports.
- 10.3 Foot straps may be added to the wings.

HOBIE SX-18

11. The Hobie SX-18 Class Rules are the same as the Hobie 18 Class Rules except as modified herein.

12. The Hobie SX-18 shall be sailed only on water surfaces greater than 400 acres (160 hectares) of open area.

13. EQUIPMENT

- 13.1 The Hobie SX-18 shall be raced with wings supplied by the HOBIE CAT CO.
- 13.2 Hiking straps may be added to the crossbars or wing supports.
- 13.3 Foot straps may be added to the wings.
- 13.4 Mainsail downhaul purchase shall not exceed 6:1 and may be rigged in any manner.
- 13.5 Jib sail downhaul purchase shall not exceed 4:1 and may be rigged in any manner.
- 13.6 Battens of any type may be used. They may be cut, shaped and tapered as desired.
- 13.7 A preventer may be added to keep the mast in rotation.

14. SPINNAKERS (THIRD SAILS) AND SPINNAKER POLES

One spinnaker may be carried on board and used on any point of sail. The spinnaker must be HOBIE CAT CO. supplied as noted by the Hobie Cat patch and factory signature on the sail. Fittings and equipment to fly the sail have the following limitations;

- a) Only a class-legal, HOBIE CAT CO. spinnaker pole may be used to fly the spinnaker.

- b) The sail cannot be attached to the mast above 23 ft. 11-1/2 in. (7.30 meters) measured from the bottom of the mast extrusion.
- c) Fittings and equipment for sheeting the spinnaker must be attached to or mounted on existing aluminium extrusions. Rigging is of open design.
- d) Spinnakers may be changed during a regatta without race committee approval. This modifies General Rule 12.3 for spinnakers only.
- e) A maximum of two spinnakers may be used per regatta.
- f) For the purpose of long distance sailing, back stays are permitted. Fittings must be attached to or mounted on existing aluminium extrusions.

15. MASTS AND BOOMS

- 15.1 The section of the mast and boom extrusions shall not be altered in any way except for the attachment of the fittings and equipment for flying sails or reefing as permitted in these rules.
- 15.2 No internal devices are allowed except as supplied.
- 15.3 The SX-18 black band shall be 27 ft. 10 in. (8.48 m) from the top of the mast not including the mast cap.

16. MINIMUM CREW WEIGHT

The minimum combined crew weight of a Hobie SX-18 shall be 310 lbs. (140.6 kg.). See Rule #17 of the General Rules.

17. MINIMUM BOAT WEIGHT

The minimum boat weight of a Hobie SX-18, completely assembled, without spinnaker, spinnaker pole and spinnaker gear, shall be 455 lbs. (206.4 kg). See Rule #19 of the General Rules.

HOBIE 18 FORMULA

18. RULES

The Hobie 18 Formula Class Rules are the same as the Hobie 18 Class Rules except as modified herein.

19. EQUIPMENT

- 19.1 The Hobie 18 Formula may be raced with or without wings supplied by the manufacturer. However, the configuration of the boat starting the first race of the regatta shall remain the same configuration for all remaining races in the regatta.

- 19.2 Hiking straps may be added to the crossbars or wing supports.
- 19.3 Foot straps may be added to the wings.
- 19.4 Mainsail downhaul purchase shall not exceed 8:1 and may be rigged in any manner.
- 19.5 Jib sail downhaul purchase shall not exceed 4:1 and may be rigged in any manner.
- 19.6 Mainsail blocks purchase shall not exceed 8:1 and may be rigged in any manner.
- 19.7 A preventer may be added to keep the mast in rotation.
- 19.8 Additional mast rotation devices and related control equipment may be installed to the owner's and/or skipper's specifications provided it does not structurally weaken the mast or the boat or interfere with factory supplied components. The HOBIE CAT CO. supplied equipment must remain in its original position on the boat. Only mainsail and jib sail supplied by the HOBIE CAT CO. will be class legal for monotype regatta or open events in Europe. Exceptions may be allowed for certain events like long distance races (where the rating is different from the original).
- 19.9 Battens of any type may be used. They may be cut, shaped and tapered as desired.
- 19.10 The maximum length of the centre board line is 15 in. (38.1 cm), measured from the top of the deck to the point of handle that can not fit in the hole, in the fully up position.
- 20. OPTIONAL THIRD SAIL (SPINNAKER)**
- 20.1 Third sail of open design may be carried on board and used on any point of the race. Fittings and equipment to fly the sail are the owner's and designer's choice. Only the spinnaker supplied by the HOBIE CAT CO. will be class legal for Hobie monotype regatta (see 19.8). For certain events, the following limitations must be applied to the conception and rigging of the third sail and apply to the third sail design:
- The open design sail cannot be attached to the mast above 8 m. (26 ft. 3 in.) measured from the bottom of the mast extrusions. Free rotating mast-tang is permitted.
 - Fittings and equipment for sheeting the open sail must be attached to or mounted on existing aluminium extrusions.
- A maximum of two open sails may be carried on board at an event and shall not be replaced during a race or regatta unless damaged and no longer usable. Race Committee approval for a replacement sail must be received prior to sail use.
 - A maximum of two open sails may be registered and identified before the start of each event. A Race Committee member's signature on the sail is acceptable identification.
 - A HOBIE CAT CO. supplied spinnaker pole including all attachments and fittings, shall not exceed the total length of 3.50 m (11 ft. 5 3/4 in.). The attachment of the spinnaker pole is normally at the middle of the front crossbar, or it may be mobile rigged allowing for bracing of the pole.
 - No more than one open sail may be flown at any one time.
 - Third sail parameters are:
Maximum luff 8.45 m. (27 ft. 8 5/8 in.)
Maximum area 20.30 m² (218.5 sq. ft.)
Spinnaker mid-girth is greater than 75% of the foot
 - Spinnaker sheet purchase shall not exceed 1:1 and may be rigged in any manner.
 - HOBIE CAT CO. spinnaker poles only are Class legal.
- 20.2 A HOBIE CAT CO. supplied barber hauler system (with chain and rope stretched across the trampoline) is permitted, provided it does not structurally weaken the boat. Barber haulers and open-sails twings must be attached only to boom or wings.
- 21. MASTS AND BOOMS**
- 21.1 The sections of the mast and boom extrusions shall not be altered in any way except for the attachment of the fittings and equipment for flying sails or reefing as permitted in these rules.
- 21.2 No internal devices are allowed except as supplied.
- 21.3 The black band shall be located between the rotation control and gooseneck.
- 22. WIRES**
- For the purpose of long distance sailing, back stays are permitted. Fittings must be attached to or mounted on existing aluminium extrusions.

HOBIE TIGER CLASS RULES

NOTE: THE HOBIE CLASS GENERAL RULES ARE PART OF THESE RULES.

1. RUDDER BLADES, RUDDER ASSEMBLIES AND DAGGER BOARDS

- 1.1 Rudder blades, rudder assemblies and dagger boards shall be stock as supplied by the HOBIE CAT CO.
- 1.2 Top edge of the dagger board in the down position shall not extend below the level of the deck into dagger board trunk.
- 1.3 Anti-chafing and shimming pads may be added to the dagger board trunk to improve fit and reduce wear. Shims must not be used to alter the angle of dagger boards.
- 1.4 HOBIE CAT CO. supplied rudder assemblies, rudder blades and dagger boards shall not be modified except for minimum filing to improve fit and function.

2. HULLS AND DECKS

No changes may be made to the hulls that decrease weight or hull strength by removing flotation or standard factory fibreglass reinforced plastic (FRP) lay-up.

3. SAILS

- 3.1 Main sail and roller furling jib 4.15 m² (43.06 sq. ft.) are to be raced as supplied from HOBIE CAT CO.
- 3.2 Any type of battens supplied by HOBIE CAT CO. is class legal. They may be cut, shaped and tapered as desired. Any type of batten caps may be used.
- 3.3 Mainsail downhaul purchase shall not exceed 16:1 and may be rigged in any manner.
- 3.4 Jib sail downhaul purchase shall not exceed 3:1 and may be rigged in any manner.
- 3.5 Reefing of any sail is permitted. Reefing design shall be open provided it does not structurally weaken the boat or interfere with basic functions of HOBIE CAT CO. supplied components.
- 3.6 Pig Tails for the purpose of attaching blocks may be added to the clew of the jib.
- 3.7 Only main, jib and spinnaker sails built from HOBIE CAT CO. approved patterns and manufactured by or for HOBIE CAT CO. are class legal.

- 3.8 A jib sheet cleat may be attached to the stay adjuster.

- 3.9 Adjustable rope luff and leech lines may be installed within existing luff and leech tapes on spinnakers.

4. MASTS

- 4.1 The mast design shall not be altered in any way except for the attachment of fittings and equipment for flying open class third sails or reefing.
- 4.2 No internal devices are allowed except as supplied.
- 4.3 A preventer, or otherwise known as a positive mast rotator, may be added to keep the mast in rotation, and may be rigged in any manner.
- 4.4 Additional mast rotation devices and related control equipment may be installed. Design shall be left open provided it does not structurally weaken the boat.
- 4.5 The black band shall be located 47 cm (18.50 inches) from the bottom of the mast extrusion to the top of the black band.
- 4.6 The head of the spinnaker shall not be hoisted higher than 8150 mm (320,866 inches) from the base of the extrusion. At the halyard block or keeper the bearing surface of the halyard shall be no more than 70 mm (2,756 inches) from the surface of the mast. For the purposes of measurement, the halyard shall be pulled tight to the tack fitting.

5. WIRES AND RUNNING GEAR

- 5.1 Running gear of any type may be used provided it is of equal strength or better than HOBIE CAT CO. supplied equivalent components.
- 5.2 Additional shroud adjusters may be added to the forestay bridle.
- 5.3 The clevis pin and ring on the forestay and/or shroud adjuster, as provided by HOBIE CAT CO., may be replaced by a quick-release pin or shackle.
- 5.4 Bridle wire lengths shall not be shorter than 1.20 meters (47.24 inches) and shall attach to the jib furler as supplied.

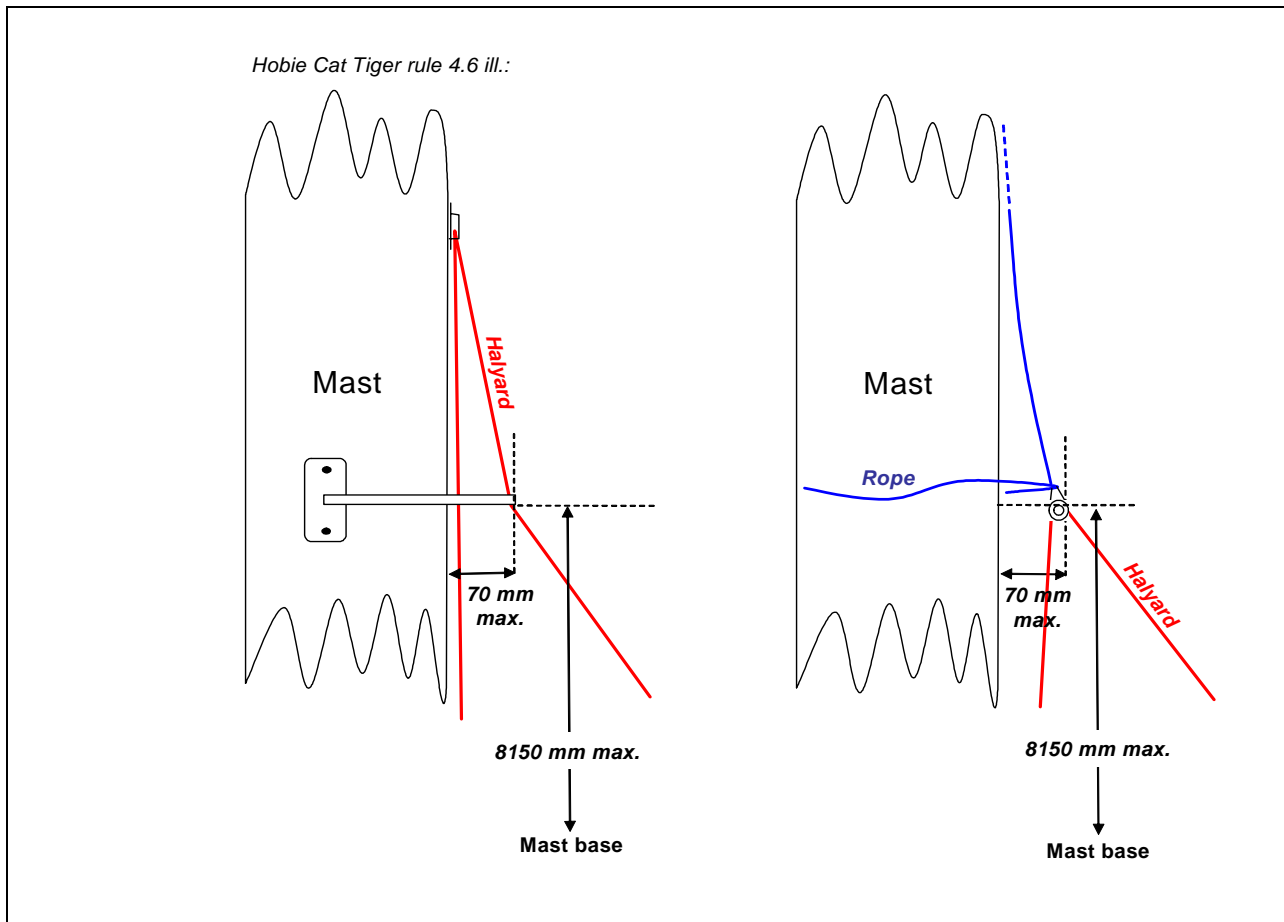

6. EQUIPMENT

- 6.1 Compasses, navigation and speed metering equipment of any type are permitted.
- 6.2 Additional safety equipment of any type is permitted.
- 6.3 Mainsheet blocks of different design or make may be used, provided the purchase advantage is equal to or less than 10:1.
- 6.4 The mainsheet system shall be of a conventional type with the lower block(s) attaching to the traveller car and the upper block(s) attaching to the boom. A wire strop to attach the upper block to the boom is permitted.
- 6.5 Jib sheet blocks of different design or make may be used provided the purchase advantage is equal to or less than 4:1. Jib cleats may be moved. Self-tacking jib system* as supplied by Hobie Cat Co. is permitted. Sheets and lines related to the self-tacker may be rigged in any manner.
* Defined as track (including its support posts and attachment fittings) and car.

Self-tacker systems for the Hobie Cat Tiger different from the Hobie Cat Co supplied system will be accepted as class legal under following provisions:

- a) Purchased before July 20, 2002 (*copy of original receipt/invoice shall act as proof if requested*).
 - b) Mounted on boats built in 2002 and prior (*as carved in the Hobie Cat Co. plaque affixed on the rear beam*).
- 6.6 Replacement blocks or fittings shall not be constructed of exotic materials such as carbon, titanium, etc.
- 6.7 Spinnaker sheet blocks of different design or make may be used. Additional blocks may be added. The spinnaker sheet blocks and spinnaker running gear may be mounted/rigged in any manner. The addition of snuffer type retrievable systems of any design, including wind-up/dog leash retrievable halyard systems are allowed. Carbon fibre material is not permitted in the snuffer.
- 6.8 Hiking straps and foot straps may be added.

- 6.9 Additional grommets may be added to the trampoline.
- 6.10 Crossbars and decks may be coated to improve footing.
- 6.11 Line(s) or elastic cord(s) may be added as tangle preventers for jib sheet lines, spinnaker and spinnaker sheet/halyard lines.
- 6.12 Safety lines are permitted.
- 6.13 Tapered sheets, lines and halyards for the spinnaker are permitted.

7. SAFETY EQUIPMENT

- 7.1 A minimum 9.5 mm (3/8 inches) diameter righting line consisting of at least one 4.9 meter (16 ft.) length of line or two 2.45 meter (8 ft.) lengths of line minimum shall be securely attached and readily accessible from each side of the boat. The righting lines shall be in addition to all other required equipment.
- 7.2 Righting water bags, righting pole type devices and shroud lengthening devices may be carried on board. Maximum extension of shroud lengthening devices are 68.6 cm (27 inches) The shroud lengthening device must be returned to its normal storage position after use and before continuing to race.

8. MINIMUM CREW WEIGHT

The Hobie Tiger shall have a minimum combined crew weight of 140 kg. (308.65 lbs).

9. MINIMUM BOAT WEIGHTS

The minimum weight of a Hobie Tiger, completely assembled with spinnaker and running gear shall be 180 kg.(396.83 lbs.). See Rule #19 of the General Rules..

10. TRAPEZES

A maximum of two trapeze wires are allowed on each side of the boat.

- 10.1 Trapeze wires may be shortened, lengthened and have adjustable systems installed.
- 10.2 Trapeze shock cords may lead from different fairleads than those supplied by the HOBIE CAT CO.

11. OPEN CLASS

In open class racing there are no limitations on spinnaker, spinnaker pole, spinnaker gear, hiking or sheeting systems. However, HOBIE CAT CO. does not condone or recommend these changes due to possible boat, gear, or component fatigue failure.

12. THIRD SAIL (SPINNAKER)) AND SPINNAKER POLE (BOWSPRIT)

- 12.1 The Hobie Tiger class spinnaker of 21 m2 (226.04 sq. ft.) as supplied by the HOBIE CAT CO. shall be carried during Class events
- 12.2 Only bowsprits supplied by a HOBIE CAT COMPANY are class legal. The bowsprit shall be fixed on the longitudinal centre line of the boat as provided by the manufacturer. Supporting wires/lines may be shortened, lengthened, mounted and/or rigged in any manner. Additional blocks/cleats for spinnaker running gear and jib luff control as well as snuffer type systems may be mounted on the bowsprit.

HOBIE 20 CLASS RULES

NOTE: THE HOBIE CLASS GENERAL RULES ARE PART OF THESE RULES.

1. RUDDER BLADES, RUDDER ASSEMBLIES AND DAGGERBOARDS

- 1.1 Rudder blades, rudder assemblies and dagger boards shall be stock as supplied by the HOBIE CAT CO. Only HOBIE CAT CO. supplied after-market rudders are allowed to replace stock rudders.
- 1.2 Dagger boards in the down position shall not extend into the dagger board trunk beyond one half the diameter of the rope handle hole.
- 1.3 Anti-chafing and shimming pads may be added to the dagger board trunk to improve fit and reduce wear. Shims must not be used to alter the angle of dagger boards.
- 1.4 HOBIE CAT CO. supplied rudder assemblies, rudder blades and dagger boards shall not be modified except for minimum filing to improve fit and function.
- 1.5 Rudder pins may be made of any material.

2. HULLS AND DECKS

No changes may be made to the hulls that decrease weight or hull strength by removing flotation or standard factory fibreglass reinforced plastic (FRP) lay-up.

3. SAILS

- 3.1 Battens of any type may be used. They may be cut, shaped and tapered as desired. Any type of batten caps may be used.
- 3.2 Mainsail downhaul purchase shall not exceed 8:1 purchase. The downhaul line must cleat on the mast or foot of the sail and may be rigged in any manner. "Cam" cleats are legal.
- 3.3 Jib sail downhaul purchase shall not exceed 4:1 and may be rigged in any manner.
- 3.4 Reefing of any sail is permitted. Reefing design shall be left to the owner's and designer's choice provided it does not structurally weaken the boat or interfere with basic functions of the HOBIE CAT CO. supplied components.
- 3.5 A roller furler may replace the HOBIE CAT CO. supplied jib tack.
- 3.6 Pig Tails for the purpose of attaching blocks may be added to the clew of the jib and the boom bale.

- 3.7 Only main and jib sails built from IHCA approved patterns and manufactured by the HOBIE CAT CO. are class legal.

4. MASTS

- 4.1 The mast design shall not be altered in any way except for the attachment of fittings and equipment for flying open class third sails or reefing.
- 4.2 No internal devices are allowed except as supplied.
- 4.3 All halyard lines running above the hounds must be nonelectrical conducting. (In North America only.)
- 4.4 A preventer may be added to keep the mast in rotation and may be rigged in any manner.
- 4.5 Additional mast rotation devices and related control equipment may be installed to the owner's and/or skipper's specifications provided they do not structurally weaken the boat or interfere with HOBIE CAT CO. supplied components.
- 4.6 The black band shall be located 19.25 inches (48.9 cm) from the bottom of the mast extrusion to the top of the black band.

5. BOOMS

- 5.1 A shock cord may be installed to remove tension on the outhaul when the outhaul line is un-cleated. The maximum purchase is 2:1
- 5.2 A turning block for outhaul adjustment line is allowed to be added to boom as long as purchase advantage is not changed.

6. WIRES AND RUNNING GEAR

- 6.1 Running gear of any type may be used provided it is of equal strength or better than HOBIE CAT CO. supplied equivalent components.
- 6.2 Additional shroud adjusters may be added to the forestay bridle.
- 6.3 The clevis pin and ring on the forestay adjuster, as provided by the HOBIE CAT CO., may be replaced by a quick-release pin, shackle or the like.
- 6.4 Bridle wire lengths shall not be shorter than 44 in. (1.12 meters).

7. EQUIPMENT

- 7.1 The Hobie 20 shall be raced without wings.
- 7.2 Compasses, navigation and speed metering equipment of any type are permitted. Radios may be used for weather information and for emergencies under the following conditions.
- a) On board radios must be OFF and stored from 1/2 hour prior to warning signal of the first race until after the finish of the last race of the day unless specified otherwise in the Notice of Race and Sailing Instructions.
 - b) If any on-board radio is on during the time restriction, the competitor shall retire immediately and notify the race committee of its action.
 - c) On board use of radios during the time restriction to monitor the race committee channel, or any other channel, shall result in a DSQ for that race. The jury may also retire the competitor from the entire series.
- 7.3 Additional safety equipment of any type is permitted.
- 7.4 Mainsheet blocks of different design or make may be used, provided the purchase advantage is equal to or less than 7:1.
- 7.5 Genoa sheet blocks of different design or make may be used provided the purchase advantage is equal to or less than 3:1.
- 7.6 Hiking straps and foot straps may be added.
- 7.7 Additional grommets may be added to the trampoline.
- 7.8 Crossbars and decks may be coated to improve footing.
- 7.9 Line(s) or bungee cord(s) may be added as tangle preventers for jib sheet lines.
- 7.10 Safety lines are permitted.
- 7.11 Inboard - outboard jib traveller systems may be permanently fixed or adjustable. Wires may be removed or modified.

8. SAFETY EQUIPMENT

- 8.1 A minimum 3/8 in. (9.5 mm) diameter righting line consisting of at least one 16 ft. (4.9 meter) length of line or two 8 ft. (2.45 meter) lengths of line minimum shall be securely attached and readily accessible from each side of the boat. The righting lines shall be in addition to all other required equipment.
- 8.2 Righting water bags, righting pole type devices, and shroud lengthening devices may be carried on board. Maximum extension of shroud lengthening devices is 27 in. (68.6 cm). The shroud lengthening device must be returned to its normal storage position after use and before continuing to race.

9. MINIMUM CREW WEIGHT

The Hobie 20 shall have a minimum combined crew weight of 295 lbs. (133.8 kg.).

10. MINIMUM BOAT WEIGHTS

The minimum weight of a Hobie 20, completely assembled, shall be 420 lbs. (190.5 kg.). See Rule #19 of the General Rules.

11. TRAPEZES

A maximum of two trapeze wires are allowed on each side of the boat.

- a) Supplied trapeze wires may be shortened, lengthened and have adjustable systems installed.
- b) Trapeze shock cords may lead from different fairleads than those supplied by the HOBIE CAT CO.

12. OPEN CLASS

In Open Class racing there are no limitations on spinnaker, spinnaker pole, spinnaker gear, hiking or sheeting systems. However, HOBIE CAT CO. does not condone or recommend these changes due to possible boat, gear, or component fatigue failure.

13. OPTIONAL OPEN CLASS THIRD SAIL (SPINNAKER)

Third sail of open design may be carried on board and used on any point of the race. Fittings and equipment to fly the sail are the owner's and designer's choice. Third sail shall be legal only for Open Class racing.

HOBIE 21 CLASS RULES

NOTE: THE HOBIE CLASS GENERAL RULES ARE PART OF THESE RULES.

1. SAFETY EQUIPMENT

- 1.1 A minimum 3/8 in. (9.5 mm) diameter righting line consisting of at least one 20 ft. (6.1 meter) length of line or two 10 ft. (3.1 meter) lengths of line minimum shall be securely attached and readily accessible from each side of the boat. The righting lines shall be in addition to all other required equipment. This modifies General Rule 8.2.
- 1.2 Maximum extension of shroud lengthening devices shall be 27 in. (68.6 cm).

2. HULLS AND DECKS

- 2.1 No changes may be made to the hulls that decrease weight or hull strength by removing flotation or standard factory fibreglass reinforced plastic lay-up.
- 2.2 Advertising and commercial messages are not permitted on the genoa (jib) or hulls forward of the front crossbar. These spaces are reserved for the IHCA. All other boat surfaces and sails may carry advertising and commercial messages.
- 2.3 Hull numbers must be distinguishable on both sides of the boat and be no less than 12 in. or more than 24 in. and located on the foremost outer section of the bow.

3. RUDDERS, RUDDER ASSEMBLIES AND CENTERBOARDS

- 3.1 HOBIE CAT CO. supplied rudder assemblies, rudder blades and centerboards shall not be modified except for minimum filing to improve fit and function.
- 3.2 The maximum length of the centerboard rope line is 21-1/2 in. (54.6 cm.) measuring from the top of the deck to the underside of the handle in the full up position.

4. TILLER ASSEMBLIES

Straight or Bent tiller crossbars and tiller arms are legal and shall be of specified length.

5. SAILS

- 5.1 Battens of any type may be used. They may be cut, shaped and tapered as desired. Any type of batten caps may be used.

- 5.2 If mainsails and optional sails have a sail number, they must correspond to the number on the hulls.
- a) Sail numbers shall be no less than 12 in. (30.5 cm) and no more than 24 in. (61 cm) in height.
- b) Sail numbers must be distinguishable on both sides of the sail.
- 5.3 Mainsail downhaul purchase shall not exceed 6:1 and may be rigged in any manner.
- 5.4 Jib sail downhaul purchase shall not exceed 4:1 and may be rigged in any manner.
- 5.5 Third sails of open design may be carried on board and used on any point of sail. Fittings and equipment to fly the sail are the owner's and designer's choice. The following limitations apply to the third sail design:
- a) The open design sail cannot be attached to the mast above 28 ft. (8.53 meters) measured from the bottom of the mast extrusion.
- b) Fittings and equipment for sheeting the open sails must be attached to or mounted on existing aluminium extrusion.
- c) A maximum of two open sails may be carried on board at an event and shall not be replaced during a race or regatta unless damaged and no longer usable. Race Committee approval for a replacement sail must be received prior to sail use.
- d) A maximum of two open sails may be registered and identified before the start of each event. A Race Committee member's signature on the sail is acceptable identification.
- e) A spinnaker pole no longer than the distance from the center line of the front crossbar to either bow may be used to fly the open sails. Rigging is of open design.
- f) No more than one open sail may be flown at any one time.
- g) Third sail parameters are:
Maximum luff 30 ft. (9.15 meters)
Maximum foot 20 ft. (6.1 meters)
Minimum S.M.G. 13 ft. (3.96 meters)

- h) Registered open sail(s) may or may not be carried on board during each race of an event.

5.6 Reefing of any sail is permitted. Reefing design shall be left to the owner's and designer's choice provided it does not structurally weaken the boat or interfere with basic functions of the HOBIE CAT CO. supplied components.

5.7 Barber hauler rings and open sail twings are permitted provided no wire or equivalent is stretched across the trampoline. Jib blocks shall remain directly attached to the jib block cars in their tracks. Rigging of barber hauler lines is open design provided it does not structurally weaken the boat or interfere with the HOBIE CAT CO. supplied components.

* Barber haulers and open sail twings shall be attached to boom or wings only.

6. MASTS

6.1 The mast design shall not be altered in any way except for the attachment of fittings and equipment for flying sails or reefing.

6.2 No internal devices are allowed except as supplied.

6.3 All halyard lines running above the hounds must be nonelectrical conducting.

6.4 A preventer may be added to keep the mast in rotation.

6.5 Additional mast rotation devices and related control equipment may be installed to the owner's and/or skipper's specifications provided they do not structurally weaken the boat or interfere with HOBIE CAT CO. supplied components.

6.6 The black band shall be located 31 ft. 11 in. (9.73 meters) from the top of the mast not including the mast cap.

7. BOOMS

A shock cord may be installed to remove tension on the outhaul when the outhaul line is uncleated. The maximum purchase is 2:1.

8. WIRES AND RUNNING GEAR

8.1 Running gear of any type may be used provided it is of equal strength or better than HOBIE CAT CO. supplied equivalent components.

8.2 Additional shroud adjusters may be added to the forestay bridle.

8.3 Bridle wire lengths shall not be shorter than 55 in. (1.4 meters).

9. EQUIPMENT

9.1 The Hobie 21 shall be raced with wings.

9.2 Compasses, navigation and speed metering equipment of any type are permitted. Radios may be used for weather information and for emergencies under the following conditions.

a) On board radios must be OFF and stored from 1/2 hour prior to warning signal of the first race until after the finish of the last race of the day unless specified otherwise in the Notice of Race or Sailing Instructions.

b) If your on-board radio is on during the time restriction, the competitor shall retire immediately and notify the race committee of its action.

c) On board use of radios to monitor the race committee channel, or any other channel, shall result in DSQ for that race. The jury may also retire the competitor from the entire series.

9.3 Additional safety equipment of any type is permitted.

9.4 Mainsheet blocks of different design or make may be used provided the purchase advantage is equal to or less than 10:1.

9.5 Genoa sheet blocks of different design or make may be used provided the purchase advantage is equal to or less than 3:1.

9.6 Hiking straps may be added provided they are attached to existing aluminium extrusions and/or trampolines.

9.7 Foot straps may be added to the wings.

9.8 Additional grommets may be added to the trampoline.

9.9 Wings, crossbars and decks may be coated to improve footing.

10. MINIMUM CREW WEIGHT

The Hobie 21 shall have a minimum combined crew weight of 330 lbs (149.7 kg).

11. MINIMUM BOAT WEIGHTS

The minimum boat weight of the Hobie 21 shall be the following:

- a) Platform (less mast, boom, rigging, trapezes, wings and sails) 420 lbs (190.5 kg)
- b) Mast, boom, double trapezes, standing and running (blocks) rigging: 100 lbs. (45.4 kg).
- c) Wings with wing trampolines: 45 lbs. (20.4 kg.)

12. OPEN CLASS

In Open Class racing, there are no limitations on spinnaker, spinnaker pole, spinnaker gear, hiking or sheeting systems. However, HOBIE CAT CO. does not condone or recommend these changes due to possible boat, gear, or component fatigue failure.

The IHCA method of measuring mainsail cross widths is to measure the distance from the leech measurement points at eighth, quarter, half, or three-quarter height to the nearest points on the luff of the sail, excluding the bolt rope, if any.

The measurement point at half height on the leech, the midpoint, is found by folding the head to the clew and equally tensioning the two halves of the leech so formed.

The eighth, quarter and three-quarter points are found similarly by folding the clew and head respectively to the midpoint.

To take the measurement from the leech to the "nearest point" on the luff, the end of the tape is held at the measurement point on the leech, while the measurer checks the measurement at various points on the luff (always applying just enough tension on the sail along the line of the measurement to remove the wrinkles across that line) until he has found the minimum reading.

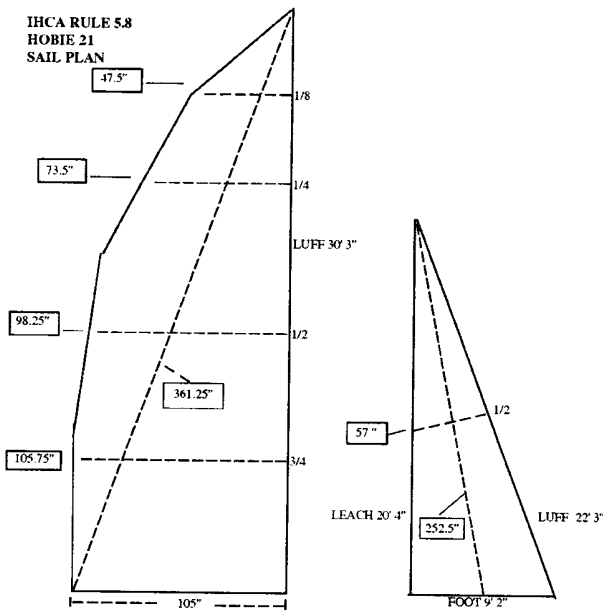

HOBIE FOX CLASS RULES

NOTE: THE HOBIE CLASS GENERAL RULES WITH EXEPTION OF RULE 13.4 ARE PART OF THESE RULES

1. RUDDER BLADES, RUDDER ASSEMBLIES AND DAGGERBOARDS

- 1.1 Rudder blades, rudder assemblies and daggerboards shall be stock as supplied by the HOBIE CAT CO.
- 1.2 Top edge of the daggerboard in the down position shall not extend below the level of the deck into daggerboard trunk.
- 1.3 Anti-chafing and shimming pads may be added to the dagger board trunk to improve fit and reduce wear. Shims must not be used to alter the angle of dagger boards.

2. HULLS AND DECKS

No changes may be made to the hulls that decrease weight or hull strength by removing flotation or standard factory fiberglass reinforced plastic (FRP) lay-up.

3. SAILS

- 3.1 Main sail, jib and spinnaker are to be raced as supplied from HOBIE CAT CO. Only main, jib and spinnaker sails built from HOBIE CAT CO. approved patterns and manufactured by or for HOBIE CAT CO. are class legal.
- 3.2 Any type of battens supplied by HOBIE CAT CO. is class legal. They may be cut, shaped and tapered as desired. Any type of batten caps may be used.
- 3.3 Mainsail downhaul purchase shall not exceed 16:1 and may be rigged in any manner.
- 3.4 Jib sail downhaul purchase shall not exceed 3:1 and may be rigged in any manner.
- 3.5 Reefing of any sail is permitted. Reefing design shall be open provided it does not structurally weaken the boat or interfere with basic functions of HOBIE CAT CO. supplied components.
- 3.6 Pig Tails for the purpose of attaching blocks may be added to the clew of the jib.
- 3.7 A jib sheet cleat may be attached to the stay adjuster.
- 3.8 Adjustable rope luff and leech lines may be installed within existing luff and leech tapes on spinnakers.

4. MASTS

- 4.1 The mast design shall not be altered in any way except for the attachment of fittings and equipment for flying open class third sails or reefing.
- 4.2 No internal devices are allowed except as supplied.
- 4.3 A preventer, or otherwise known as a positive mast rotator, may be added to keep the mast in rotation, and may be rigged in any manner.
- 4.4 Additional mast rotation devices and related control equipment may be installed. Design shall be left open provided it does not structurally weaken the boat.
- 4.5 The black band shall be located 47 cm (18.50 inches) from the bottom of the mast extrusion to the top of the black band.
- 4.6 The head of the spinnaker shall not be hoisted higher than 8200 mm (322,835 inches) from the base of the extrusion. At the halyard block or keeper the bearing surface of the halyard shall be no more than 70 mm (2,756 inches) from the surface of the mast. For the purposes of measurement, the halyard shall be pulled tight to the tack fitting.

5. WIRES AND RUNNING GEAR

- 5.1 Running gear of any type may be used provided it is of equal strength or better than HOBIE CAT CO. supplied equivalent components. Tapered sheets are not allowed.
- 5.2 Additional shroud adjusters may be added to the forestay bridle and/or to the forestay at the mast tang.
- 5.3 Bridle wire lengths shall not be shorter than 118 cm (46.46 inches) and shall attach to the jib furler as supplied.

6. EQUIPMENT

- 6.1 Additional safety equipment of any type is permitted.
- 6.2 Mainsheet blocks of different design or make may be used, provided the purchase advantage is equal to or less than 10:1.

- 6.3 The mainsheet system shall be of a conventional type with the lower block(s) attaching to the traveller car and the upper block(s) attaching to the boom. A wire strop to attach the upper block to the boom is permitted.
- 6.4 Jib sheet blocks of different design or make may be used provided the purchase advantage is equal to or less than 4:1. Jib cleats may be moved. Self-tacking jib system* as supplied by

Carbon fibre material is not permitted in the snuffer.

- 6.7 Hiking straps and foot straps may be added.
- 6.8 Additional grommets may be added to the trampoline.
- 6.9 Crossbars and decks may be coated to improve footing.

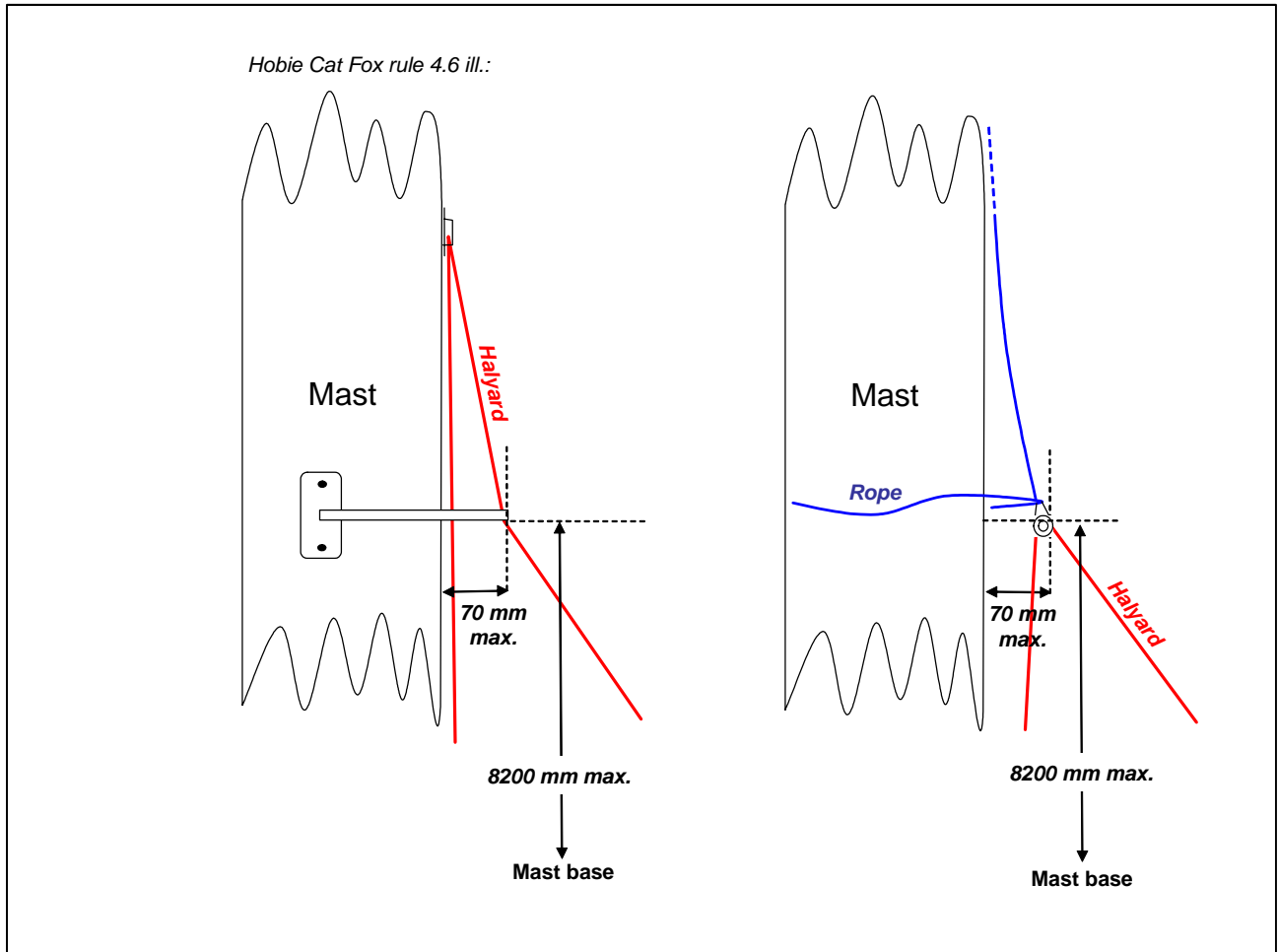

Hobie Cat Co. is permitted. Sheets and lines related to the self-tacker may be rigged in any manner.

* Defined as track (including its support posts and attachment fittings) and car.

- 6.5 Replacement blocks or fittings shall not be constructed of exotic materials such as carbon, titanium, etc.
- 6.6 Spinnaker sheet blocks of different design or make may be used. Additional blocks may be added. The spinnaker sheet blocks and spinnaker running gear may be mounted/rigged in any manner. The addition of snuffer type retrievable systems of any design, including wind-up/dog leash retrievable halyard systems are allowed.
- 6.10 Line(s) or elastic cord(s) may be added as tangle preventers for jib sheet lines, spinnaker and spinnaker sheet/halyard lines
- 6.11 Safety lines are permitted.
- 6.12 Tapered sheets, lines and halyards for the spinnaker are permitted.
- 6.13 Wings as supplied by Hobie Cat Co. are permitted during racing. Overall beam not to exceed 3.80 meters (12,47 ft.).

7. SAFETY EQUIPMENT

7.1 A minimum 9.5 mm (3/8 inches) diameter righting line consisting of at least one 4.9 meter (16 ft.) length of line or two 2.45 meter (8 ft.) lengths of line minimum shall be securely attached and readily accessible from each side of the boat. The righting lines shall be in addition to all other required equipment.

7.2 Righting water bags, righting pole type devices and shroud lengthening devices may be carried on board. Maximum extension of shroud lengthening devices are 68.6 cm (27 inches) The shroud lengthening device must be returned to its normal storage position after use and before continuing to race.

8. MINIMUM CREW WEIGHT

The Hobie Fox shall have a minimum combined crew weight of 150 kg (330.70 lbs)

9. MINIMUM BOAT WEIGHTS

The minimum weight of a Hobie Fox, completely assembled with spinnaker and running gear shall 190 kg (418.88 lbs.) See Rule #19 of the General Rules.

10. TRAPEZES

A maximum of two trapeze wires are allowed on each side of the boat.

10.1 Trapeze wires may be shortened, lengthened and have adjustable systems installed.

10.2 Trapeze shock cords may lead from different fairleads than those supplied by the HOBIE CAT CO.

11. OPEN CLASS

In open class racing there are no limitations on spinnaker, spinnaker pole, spinnaker gear, hiking or sheeting systems. However, HOBIE CAT CO. does not condone or recommend these changes due to possible boat, gear, or component fatigue failure.

12. THIRD SAIL (SPINNAKER) AND SPINNAKER POLE (BOWSPRIT)

12.1 The Hobie Fox class spinnaker of 25 m² (269.10 sq. ft) as supplied by the HOBIE CAT CO. shall be carried during Class events.

12.2 Only bowsprits supplied by a HOBIE CAT COMPANY are class legal. The bowsprit shall be fixed on the longitudinal centerline of the boat as provided by the manufacturer. Supporting wires/lines may be shortened, lengthened, mounted and/or rigged in any manner. Additional blocks/cleats for spinnaker running gear and jib luff control may be mounted on the bowsprit

Appendix A:

TRAPSEAT GUIDELINES FOR THE HOBIE 16

NOTE: These guidelines are meant as guidelines only and do not have status as class rules. It must be handled through Notice of Race and Sailing Instructions, if the guidelines (or part of them) shall be used as rules.

1. FORMAT

A Hobie Cat 16 with trapseats shall be sailed by a helmsperson and crew. Crew shall number one except where race organisers rule that crew in all craft shall number two.

2. HELMSPERSON

2.1 The helmsperson shall be disabled i.e. shall be classifiable according to that version of the IFDS Functional Classification System current at the time of the championship.

OR

2.2 The helmsperson may be able-bodied or disabled.

3. CREW

The crew may be able-bodied or disabled.

4. NUMBER OF TRAPSEATS

There shall be two trap seats attached to each boat.

5. HIKING

The crew may hike from any position.

6. POSITION WHEN RACING

When racing, no part of the torso of the helmsperson shall pass the centre line of the boat.

7. CAPSIZE

Rule 6 shall not apply in the event of a capsize.

8. NOMINATION OF STEERING SIDE

Before each race, each helmsperson shall nominate the side of the boat from which he/she will steer the boat.

9. DISQUALIFICATION

No competitor will be disqualified due to assistance received in the event of a capsize or other emergency deemed such by the race organisers.

Appendix B

IHCA Supplement to the International Hobie Cat 16 Class Rules. THE USE OF THE SPINNAKER IS ONLY AUTHORIZED FOR SPECIAL YOUTH EVENTS.

1. The IHCA General Class Rules and the Hobie Cat 16 Class Rules are part of these rules.
2. Only spinnaker sails, bowsprits and snuffer kits built from HOBIE CAT CO. approved patterns and manufactured by or for HOBIE CAT CO. are class legal.
3. The Hobie 16 class spinnaker of maximum 17,65 m², the bowsprit of 3200mm length (+/- 5 mm) and the snuffer as supplied by a HOBIE CAT CO. shall be carried during class events when this supplement is in force.
4. The bowsprit shall be fixed on the longitudinal centre line of the boat as provided by the manufacturer. Bowsprits shall have a blunt end cap fitted. Bowsprit bridle wire length shall not be shorter than 1595 mm. Additional supporting lines for the bowsprit may be mounted and/or rigged in any manner.
5. The head of the spinnaker shall not be hoisted higher than 6865 mm from the base of the extrusion. At the halyard block or keeper the bearing surface of the halyard shall be no more than 70 mm from the surface of the mast. For the purposes of measurement, the halyard shall be pulled tight to the tack fitting.
6. Spinnaker sheet blocks of different design or make may be used. Additional blocks may be added. The spinnaker sheet blocks and spinnaker running gear may be mounted/rigged in any manner.
7. Tapered sheets, lines and halyards for the spinnaker are permitted.
8. Line(s), elastic cord(s) and covers may be added as tangle preventers for jib sheet lines, spinnaker and spinnaker sheet/halyard lines.
9. Adjustable rope luff and leech lines may be installed within existing luff and leech tapes on spinnakers.

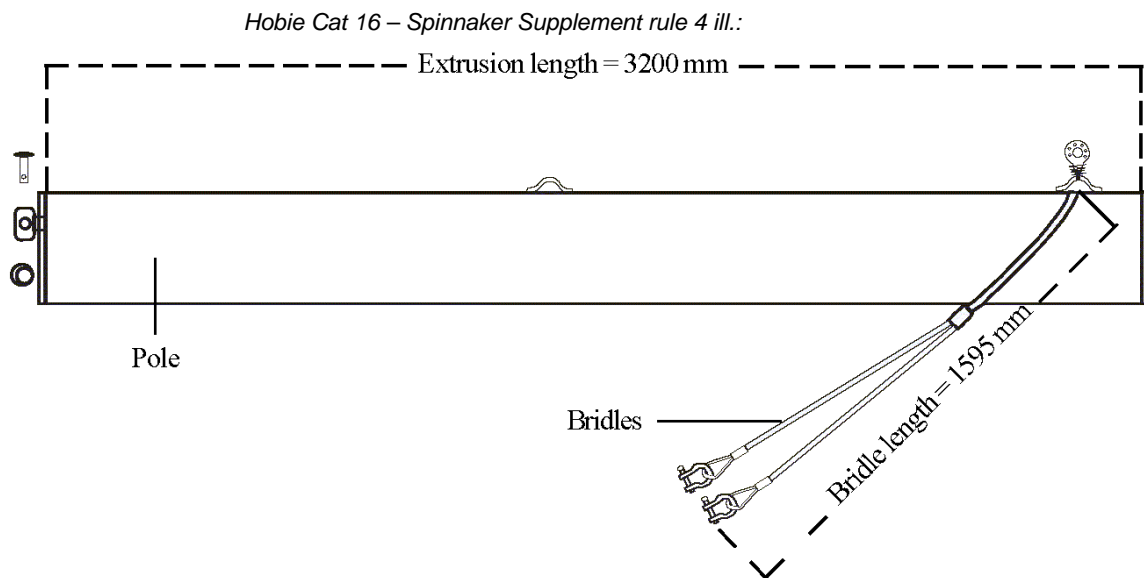

Hobie Cat 16 – Spinnaker Supplement rule 5 ill.:

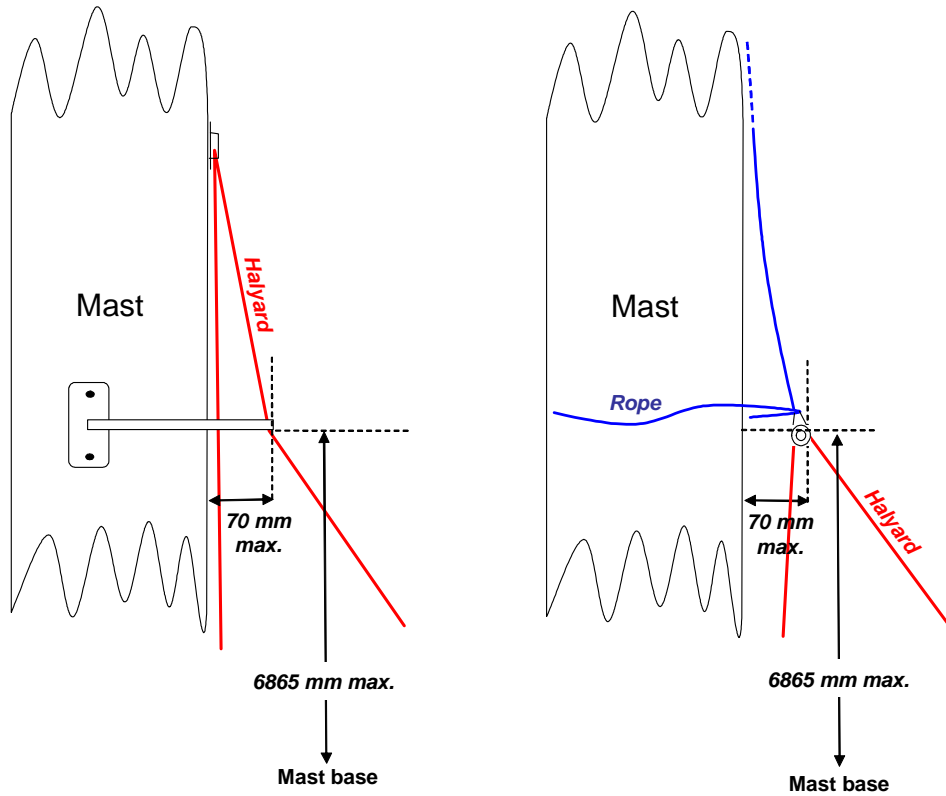

Copy of the IHCA MEASURERS ADMINISTRATION Bylaw

1. MEASURERS ADMINISTRATION

The IHCA Rules Committee shall be responsible for administering the Measurer's programme. The responsibilities of an IHCA measurer include:

- a. communicating – with the help of the IHCA Rules Committee which includes publishing and distributing the Class Rules Changes; addressing questions from their Regional/National Class Association; disseminating any other relevant information;
- b. proposing changes to the IHCA Rules Committee;
- c. dealing with such matters as any IHCA Committee may request.

2. REQUIREMENTS FOR APPOINTMENT AS AN IHCA MEASURER

A candidate for Appointment shall be nominated by his or her country's/region's Hobie Association.

3. QUALIFICATIONS FOR AN IHCA MEASURER

A candidate for initial appointment as an IHCA Measurer shall:

- a. have an intimate knowledge of the IHCA Class Rules and the ISAF
- b. have a working understanding of Measurement Rules;
- c. have an ability to apply the relevant rules and make correct decisions;
- d. have the necessary technical skills;
- e. display the temperament and behaviour expected from an Measurer at a principal event;
- f. contribute to development of the IHCA Rules Committee and further the objectives, rule of the IHCA;
- g. a Measurer should not be employed by or be a consultant to a Hobie Cat Manufacturer.

4. CONSIDERATIONS FOR APPOINTMENT OR RE-APPOINTMENT

In addition, the IHCA Rules Committee shall consider the following when considering an application:

- a. any comments received through the ISAF;
- b. the candidate's experience in measurement;
- c. other information as it may consider relevant.

5. TERMINATION OF APPOINTMENT

The IHCA Rules Committee may at any time and for any reason recommend to the IHCA Council the termination of a measurer's appointment.

Appendix D -

IHCA Contacts

IHCA Contacts

Paul Ulibarri, IHCA President - 3334 Fulton Victoria BC V9C 2T9 CANADA Tel: + 1 250 474 7580
Email: ulibarri@shaw.ca

David Brookes, IHCA Executive Director - 18 Arafura Crescent, Tingalpa 4173 QLD, AUSTRALIA
Tel: + 61 7 3890 5224 / Fax + 61 7 33489923/ Email: david.brookes@hobieclass.com

Fritz-R Klocke, IHCA Vice President - 1160 Pond Cypress Dr Virginia Beach, VA 23455 USA
Tel/fax: 1-757-490-8587 EMAIL. frklocke@aol.com

Lori Mohney ,IHCA Vice President-2812 E. Shore Dr.Portage, MI 49002
Tele +1-269-327-4565 e-mail: miracle429@aol.com

Gordon McGillivray, Africa Region Chairman - PO Box 1195, Milnerton 7435, Cape Town SOUTH AFRICA Tel : + 27 21 552 9576 / Fax: + 27 21 552 9388 / Email: gordon@hobiecat.co.za

Geert Schouten, EHCA President - Ambrozijnberg 161, NL 4707 MP Roosendaal NETHERLANDS Tel: +31 165 570223 / Fax: +31 165 570225 / Mob: +31 6 53643022 /Email: geert.schouten@haveahobieday.com

Ed Muns, HCA North America Region Chairman - PO Box 1877 Los Gatos CA 95031-1877 Tel + 408-515-2663 Email: ed@munsvineyard.com

Tony Stearns, North Pacific Region Chairman - PO Box 5218, Saipan MP 96950-5218 USA Tel: + 1 670 256 3222 / Fax: + 1 670 256 3220 / Email: tstearns@itecnmi.com

Ricardo Navarro, South American Regional Chairman Av. Othon Gama D'Éça 809, apto 203 - Centro 88015-240 - Florianópolis - SC - Brazil T+ 55 (48) 222-4769 Email: ricnavar@yahoo.com

Kevin Winchester, South Pacific Region Chairman - 51 Bottlebrush Drive NSW 2261 AUSTRALIA
Tel + 61 2 4381059 Fax +61 2 43881059 EMAIL southpacrep@hobieclass.com

Rich McVeigh, International Region Chairman 14813 Fireside Dr Silver Spring MD 20905
Tel + 1 301 384 3695 WK +1 301 435 7795 EMAIL rmcveigh@starpower.net

Jeff Alter, Alter Family Representative, Chair IHCA Rules Committee - 305 E Park, PMB 199, McCall ID 83638-3804 USA Tel: + 1 208 634 3912 / Fax: + 1 208 634 4116 /
Email: jeffa@hobie.com

Steve Fields, Managing Director Hobie Cat Australasia - Unit 1, Lot 111 Erina Road Huskisson NSW 2540 AUSTRALIA Tel: + 61 2 44 418 400 / Fax: + 61 2 44 418 444 /
Email: hobie@hobiecat.com.au

Daan van der Klugt, President Hobie Cat Brasil - R Elizeu, Visconti 95, Sao Paul SP 05683-010 BRASIL Tel/Fax: + 55 11 3758 0915 / Home: + 55 11 3758 9234 / Email: daan@hobiecat.com.br

John Dinsdale, Hobie Cat Europe, IHCA Rules Committee - ZI Toulon-EST, BP 250, F-83078
Toulon Cedex 9 FRANCE Tel: + 33 4 94 08 78 78 / Fax: + 33 4 94 08 13 99 /
Email: hobiecat@hobie-cat.net

Doug Skidmore, President Hobie Cat USA, IHCA Rules Committee - 4925 E Oceanside Blvd,
Oceanside CA 92056-3044 USA Tel: +1 760 758 9100 / Fax: +1 760 758 1841 /
Email: dskidmore@hobieco.com

Erik Olsen, IHCA Rules Committee - Svenstrup Strand 3 DK 5500 Middlefart DENMARK Tel: + 45
64 40 31 38 / Mob: + 45 25 77 88 01 / Email: olsen.dk@get2net.dk

Mal Gray, IHCA Rules Committee - 389 Lake Macdonald Drive Cooroy, Sunshine Coast 4563
Queensland Australia Telephone : (07) 5447 6317/ Email: mal@sunstatehobie.com.au

IHCA Past President - Thomas Poulsen - Eivindsvej 19, 2920 Charlottenlund DENMARK
Tel: + 45 39 63 73 07 / Fax: + 45 39 19 30 31 / Email: thomas.poulsen@hobieclass.com